



A SOLID CONNECTION®

PRODUCT GUIDE

ANCHOR DESIGN SOFTWARE NOW AVAILABLE WITH SEISMIC LOAD CALCULATION

The most easy to use anchor design software has been improved to also be the most powerful. The MKT Anchor Design software allows the designer to calculate seismic loads, including applying the Ω_0 factor for your application. All seismic calculations are according to ACI 318 and allow the designer to evaluate every load factor and load combination possible. Couple this new seismic tool with the flexibly ridge base plate evaluation tool and you get the most powerful, most versatile design package for anchor calculations available today. Simplify your anchor design calculations by downloading your copy from the Resources tab at www.MKTfasteningUSA.com. MKT Fastening ...a solid connection.

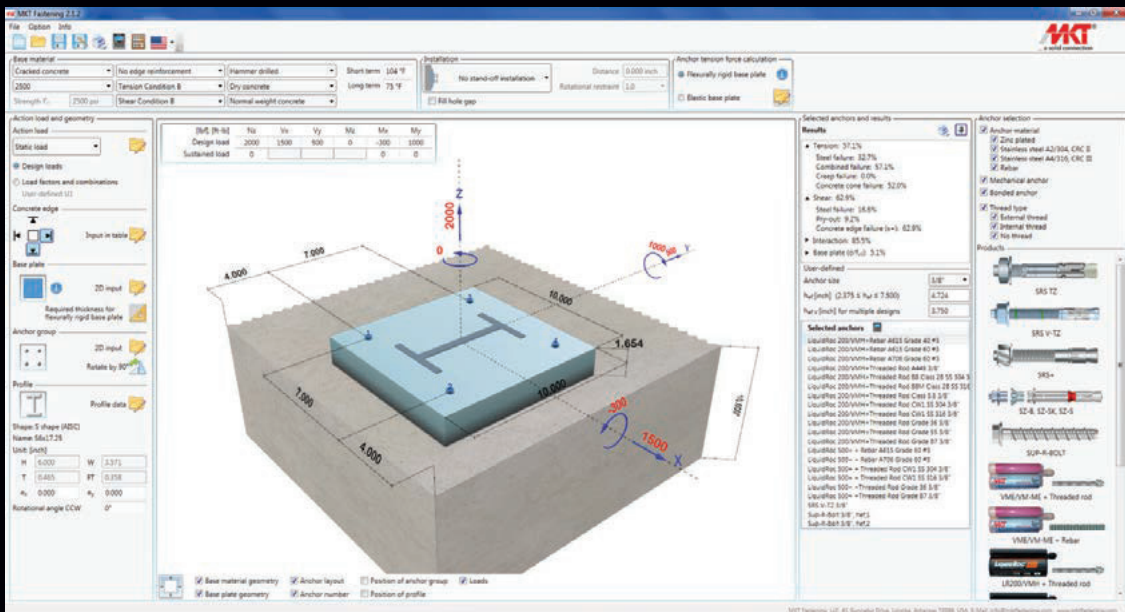

1 Gunnebo Drive
Lonoke, Arkansas 72086
(800) 336-1640
(501) 676-2222
www.MKTfasteningUSA.com
info@MKTfasteningUSA.com

ABOUT US

Founded in 1911, MKT Fastening, LLC manufactures reliable mechanical and adhesive anchoring and fastening systems in the USA. With over a century of experience, we have built trusted partnerships with distributors, customers, and suppliers in the construction industry.

We have invested in our production capabilities by upgrading our production equipment, allowing us to serve as a flexible partner that meets our customers' needs. Our shelves are stocked, and we are ready to fill your warehouse with top-quality fastening and anchoring systems.

We focus on building lasting relationships with our customers offering reliable solutions and serving as a flexible partner. If you are looking for reliable mechanical or adhesive anchoring systems, proudly made in the USA, we are ready to partner with you!

**Build your projects with confidence,
knowing you are supported by
DURABLE, AMERICAN-MADE PRODUCTS,
FREE FROM TARIFFS AND WORRIES!**



OUR HISTORY

1911



U.S. EXPANSION BOLT

U.S. Expansion Bolt is founded in New York, making quality mechanical expansion anchors. In 1934, the company moves to York, Pennsylvania and becomes USE. Later, the name is changed to USE Diamond.

U.S. EXPANSION BOLT

Our legacy of innovation began in 1912 with first patents for improvements in expansion bolt anchors.

1912

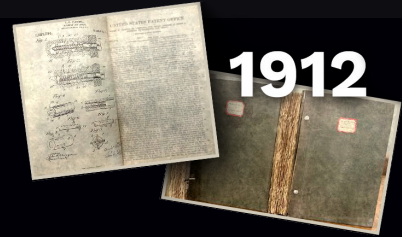

1934



FIRST PATENTS

We move to York, Pennsylvania and become USE Diamond. The USE product line consisted of high quality mechanical expansion anchors.

TAPER BOLT

We invented the Taper Bolt – a high strength concrete fastener and expansion anchor that set new standards in performance and reliability.

1972



1990



GUNNEBO FASTENING

Gunnebo Fastening acquires USE Diamond and merges with Uniset, creating a line of powder-actuated tools and the corresponding pins and powder loads. The USE base product line was high-quality mechanical expansion anchors. In 1985, the company developed an adhesive anchor to continue finding customer solutions.

LONOKE, ARKANSAS

The facility in York closes, and all operations are moved to Lonoke, Arkansas.

1995



1998



MKT FASTENING

The Germany-based 'MKT GmbH & Co. KG' expanded production and established 'MKT Fastening, LLC' in Arkansas. We developed customized solutions and were able to offer a complete range of metric and fractional products for the US market.

THAT'S A SOLID CONNECTION.

We aim to build partnerships with our customers, distributors, and suppliers to be as strong as the products we produce.

TODAY



TABLE OF CONTENTS

We make products as reliable and innovative as the people who use them. Today, we are the only company in the world manufacturing American-made plastic, mechanical and chemical injection anchoring systems. And we offer the best service and availability across the country. It's the MKT way.

MADE IN THE USA ANCHORING SYSTEMS

- 10 Sup-R Stud® +
- 12 Forway
- 13 Taper Bolt®
- 14 Tap-It®
- 14 Tap-It® Nylon Washer
- 15 Uni-Tap

HEAVY DUTY ANCHORING SYSTEMS

- 18 SZ High Load Anchor

MEDIUM DUTY ANCHORING SYSTEMS

- 22 Sup-R Drop®
- 23 Coil Thread Sup-R Drop®
- 23 Sup-R Shorty & Lipped Sup-R Drop
- 24 Sup-R Bolt
- 26 Sup-R Sleeve
- 28 Sup-R Stud® TZ
- 30 Sup-R Stud® TZ SS
- 32 Sup-R Stud® V-TZ
- 34 Sup-R Stud® + Internal Thread

LIGHT DUTY ANCHORING SYSTEMS

- 37 Sup-R Caulk®
- 37 Sup-R Lead®
- 38 Sup-R Toggle®
- 38 Plastic Screw Anchor
- 39 Conset®
- 40 Sup-R Split®
- 41 Import® Single
- 41 Import® Double
- 41 Self-Drilling Wallbaord
- 42 Holly
- 43 Sup-R Lag
- 43 Zap-It®

ADHESIVE ANCHORING SYSTEMS

- 46 General Information
- 47 Liquid Roc® 200
- 49 Liquid Roc® 300 Capsule
- 50 Liquid Roc® 300 Pouch
- 51 Liquid Roc® 300 Twin Tube
- 52 VMZ Internal Thread Injection System
- 53 EP 800 Pure Epoxy
- 55 Liquid Roc® 700+

GENERAL INFORMATION

KEY: ● Very Suitable ○ May Be Suitable Per Application

APPLICATION AND PRODUCT SELECTION GUIDE																	
Anchors		Fastening Base Material								Application Criteria					Program		
Page No.	Types of Anchors	Concrete	Cracked Conc.	Hard Natural Stone	Soft Natural Stone	Solid/Hollow	Grout Filled Block	Hollow Concrete Block	Wood/Metal	In-place (through) Fastening	Immediate Loading	Flush Surface Removing	Dynamic Loading	Temp Resistant	Materials	Versions	Characteristics
HEAVY DUTY																	
13	Taper Bolt	●	○	○						●	●	●	●	●	- Grade 5 Steel Zinc Plated - Mechanically Galv. - Stainless Steel	- Hex Head Bolt - Eye Bolt	Metal expansion/ caulking anchor with large expander sleeve
18	SZ High Load Anchor	●	●	○						●	●	●	●	●	- High Strength Steel - 316 Stainless Steel	- Stud Bolt - Flat Head	Expansion of steel sleeve by an internal cone with the matching taper.
MEDIUM DUTY																	
24	Sup-R-Bolt	●	●	○	○	○	●	○		●	●	●	●	●	Zinc Plated Steel 316 Stainless Steel	Hex Head Bolt	cuts into concrete or
28	Sup-R-Stud TZ	●	●	○						●	●		●	●	- Zinc Plated Steel - 304 / 316 Stainless Steel	- UNC Male Screw Thread	Expansion of stainless steel collar by tapered stud body
30	Sup-R-Stud TZ SS	●	●	○						●	●		●	●	- Zinc Plated Steel - 304 / 316 Stainless Steel	- UNC Male Screw Thread	Expansion of a steel collar by a tapered stud body
32	Sup-R-Stud V-TZ	●	●	○				○		●	●		○	●	- Zinc Plated Steel	- UNC Male Screw Thread	Expansion of a steel collar by a tapered stud body
10	Sup-R Stud +	●		○				○		●	●			●	- Zinc Plated Steel - Mechanically Galv. - 303/304 Stainless Steel - 316 Stainless Steel - Grade 5 steel	- UNC Male Screw Thread - Tie Wire	Expansion of stainless steel collar by tapered stud body
34	Sup-R Stud + Internal Thread	●		○				○		●	●	●	●	●	- Zinc Plated Steel - 304 / 316 Stainless	- UNC Female Screw Thread	Expansion of a steel collar by a tapered stud body
22	Sup-R-Drop	●		○				○		●	●		●	●	- Zinc Plated Carbon Steel - 304 Stainless Steel - 316 Stainless Steel	- UNC Female Screw Thread	Expansion of anchor wall by internal tapered plug
23	Coil Threaded Drop	●		○						●	●		●	●	- Zinc Plated Carbon Steel	- Female Coil Thread	Expansion of anchor wall by internal tapered plug
23	Sup-R-Shorty Drop	●		○						●	●		●	●	- Zinc Plated Carbon Steel	- UNC Female Screw Thread	Expansion of anchor wall by internal tapered plug
26	Sup-R-Sleeve	●		○	○	○	●	●		●	●	○	●	●	- Zinc Plated Carbon Steel - 304 Stainless Steel	- Acorn Head - Hex Head - Round Head - Flat Head	Expansion of steel sleeve by tapered body
12	Forway	●		○	○	○	○	○		●	●	○	○	○	- Zinc Diecast Alloy	- UNC Female Screw Thread	Four way expansion of anchor wall by internal nut
LIGHT DUTY																	
43	Sup-R Lag	●		●	○	○	○			●	●			○	- Zinc Diecast Alloy	- Female Lag Screw Threads	Body of shield separates when installing lag screw
39	Conset	●		●			●	●	○	●	●	●	○	○	- High Strength Steel CR10 Coating	- Hex Head - Phillips Flat Head	Hardened screw thread cuts into concrete or masonry
40	Sup-R Split	●		●	○	○	○			●	●			●	- Zinc Plated High Strength Steel - CR plated - ACQ Approved	- Flat Head	Fastener exerts compressive force against wall of hole
41	Import Single & Double	●		○	○		○			●	●		○	○	- Zinc Diecast Alloy	- UNC Female Screw Threads	Expansion of anchor wall by internal nut
37	Sup-R-Caulk	●		●	●	●	○			●	●				- Lead Shield w/Zinc Expansion nut	- UNC Female Screw Threads	Outer sleeve expanded by driving over plug
37	Sup-R-Lead	●		●	●	●	○			●	●				- Lead Diecast Alloy	- Wood Screw	Screw forms lead to hole wall
38	Sup-R Toggle				○			○	●	●	●	●	○		- Zinc Plated Steel Stamping	- Spring Wing Round, Flat, Mushroom or Hanger Type	Legs Expand behind wall to provide keying hold
38	Plastic Screw Anchor	●		●	●	●	○	○	●	●	●				- Polypropylene	- Wood Screw	Screw forms plastic to hole wall
14	Tap-It	●		○	○	○	○	○	○	○	○			○	- Steel and Aluminum Nail	- Mushroom Heads - Round Heads - Flat Heads	Expansion of body by impact on nail head
15	Uni-Tap	●		○	○	○	○	○	○	○	○			○	- Nylon	- Mushroom Head	Hold by reverse tension of flutes
43	Zap-It	●		●	●	●	●	○		●	●			○	- Zinc Diecast Alloy - Carbon Steel - Zinc Plated Nail - Stainless Steel Nail	- Mushroom Head	Expansion of body by impact of nail head
41	Wallboard Anchor	○			○				●	●	●	○	○		- Zinc Diecast Alloy - Nylon	- Screw	Oversized threads cut into wall board
42	Holly							○	●	●	●	●	○		- Zinc Plated Sheet Metal	- Regular and Drive	Legs expand behind wall to provide keying hold

Drill Bits meet ANSI B212.15



MADE IN THE USA

ANCHORING SYSTEMS

SUP-R[®] STUD[®] +

AVAILABLE MATERIALS

- Carbon steel, zinc plated
- Carbon steel, mechanically galvanized Class 65
- Grade 5, yellow di-chromated
- 303/304 stainless steel
- 316 stainless steel

FEATURES/ADVANTAGES

- Anchor and hole share the same diameter for a tight fit
- Fast installation with immediate load-bearing capability
- Allows installation in bottomless holes for simple and hassle-free setting
- Nut and washer supplied in package
- ROHS compliant except for Grade 5
- Custom thread lengths available by special order.

APPROVALS/LISTINGS

- G.S.A. Spec A-A-1923A, CID TYPE 4
- ICC ESR-3782 C-STL, ZP 1/4" SS
- Contact customer service for approvals / listings for state D.O.T.'s

CONSIDERATIONS

- Do not use in brick or block
- Not advised for use where vibratory loads are high
- Oversize holes are detrimental and will reduce load performance

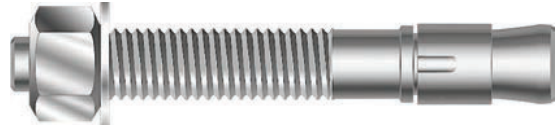

Anchor Spacing / Edge Distance

Anchor Diameter	Nominal Embedment	Min. Anchor Spacing*	Min. Edge Distance*
1/4"	1-1/2"	2-1/2"	1-1/4"
3/8"	2-7/16"	3-3/4"	1-7/8"
1/2"	2-9/16"	5"	2-1/2"
5/8"	3-3/8"	6-1/4"	3-1/8"
3/4"	4-5/8"	7-1/2"	3-3/8"
7/8"	4"	8-3/4"	4-3/8"
1"	4-1/2"	10"	5"
1-1/4"	6-1/2"	12-1/2"	6-1/4"

* To obtain 100% load

INSTALLATION

1 Select the correct diameter drill bit, drill a hole to minimum required hole depth or deeper.

2 Remove drilling debris from the bottom of the drill hole using a brush and a blowout bulb, compressed air or vacuum.

3 Assemble the nut & washer past the impact end of the

SRS V-TZ. Use a hammer to tap the anchor through the part being fastened into the drilled hole until the washer is in contact with the part.

4 Using a torque wrench, apply the specified installation torque.

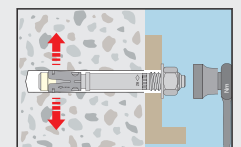
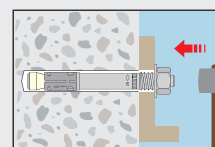
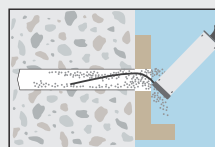
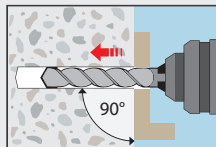

ORDER DETAIL

Anchor Diameter & Length	Carbon Steel		Galvanized		303/304 Stainless		316 Stainless		Grade 5 Steel		Hole Diameter	Length ID	Max Thk Mat to be Anchored	Required Torque to Set (ft. lbs.)	Box Qty.	Master Qty.
	Order Code	Thread Length Min	Order Code	Thread Length Min	Order Code	Thread Length Min	Order Code	Thread Length Min	Order Code	Thread Length Min						
1/4" x 1-1/2"	2614TIE	-	-	-	-	-	-	-	-	-	1/4"	-	-	-	100	800
1/4" x 1-3/4"	2614134	7/8"	2814134	7/8"	2714134	7/8"	271413S	7/8"	2514134	7/8"	1/4"	A	3/8"	8-10	100	800
1/4" x 2-1/4"	2614214	1-3/8"	2814214	1-3/8"	2714214	1-3/8"	271421S	1-3/8"	2514214	1-3/8"	1/4"	B	7/8"	8-10	100	800
1/4" x 3-1/4"	2614314	2-1/4"	2814314	2-1/4"	2714314	2-1/4"	271431S*	2-1/4"	2514314	2-1/4"	1/4"	D	1-7/8"	8-10	100	800
3/8" x 2-1/4"	2638214	1-1/4"	2838214	1-1/4"	2738214	1-1/4"	273821S*	1-1/4"	2538214	1-3/16"	3/8"	B	1/4"	15-30	50	400
3/8" x 2-3/4"	2638234	1-5/8"	2838234	1-5/8"	2738234	1-5/8"	273823S*	1-5/8"	2538234*	1-5/8"	3/8"	C	3/4"	15-30	50	400
3/8" x 3"	2638300	1-7/8"	2838300	1-7/8"	2738300	1-7/8"	273830S	1-7/8"	2538300	1-7/8"	3/8"	D	1"	15-30	50	400
3/8" x 3-3/4"	2638334	2-5/8"	2838334	2-5/8"	2738334	2-5/8"	273833S	2-5/8"	2538334	2-5/8"	3/8"	E	1-3/4"	15-30	50	400
3/8" x 5"	2638500	3-7/8"	2838500	3-7/8"	2738500	3-7/8"	273850S*	3-7/8"	2538500	4"	3/8"	H	3"	15-30	50	250
1/2" x 2-3/4"	2612234	1-1/4"	2812234	1-1/4"	2712234	1-1/4"	271223S	1-1/4"	2512234	1-1/2"	1/2"	C	1/8"	25-50	50	150
1/2" x 3-3/4"	2612334	2-1/4"	2812334	2-1/4"	2712334	2-1/4"	271233S*	2-1/4"	2512334*	2-1/2"	1/2"	E	1"	25-50	50	150
1/2" x 4-1/4"	2612414	2-3/4"	2812414	2-3/4"	2712414	2-3/4"	271241S	2-3/4"	2512414	3"	1/2"	F	1-1/2"	25-50	50	150
1/2" x 5-1/2"	2612512	4"	2812512	4"	2712512	4"	271251S*	4"	2512512	4"	1/2"	I	2-3/4"	25-50	50	150
1/2" x 7"	2612700	4-1/2"	2812700	4-1/2"	2712700	4-1/2"	271270S*	4-1/2"	2512700	4"	1/2"	L	4-1/4"	25-50	25	75
1/2" x 8-1/2"	2612812	4-1/2"	2812812	4-1/2"	2712812*	4-1/2"	271281S*	4-1/2"	2512812	4"	1/2"	O	5-3/4"	25-50	25	75
5/8" x 3-1/2"	2658312	1-5/8"	2858312	1-5/8"	2758312	1-5/8"	275831S*	1-5/8"	2558312	1-5/8"	5/8"	E	1/8"	40-75	25	75
5/8" x 4-1/2"	2658412	2-5/8"	2858412	2-5/8"	2758412*	2-5/8"	275841S*	2-5/8"	2558412	2-5/8"	5/8"	G	1-1/8"	40-75	25	75
5/8" x 5"	2658500	3-1/4"	2858500	3-1/4"	2758500	3-1/4"	275850S	3-1/4"	2558500	3-1/4"	5/8"	H	1-5/8"	40-75	25	75
5/8" x 6"	2658600	4"	2858600	4"	2758600	4"	275860S*	4"	2558600	4-1/8"	5/8"	J	2-5/8"	40-75	25	75
5/8" x 7"	2658700	4"	2858700	4"	2758700*	4"	275870S*	4"	2558700	4"	5/8"	L	3-5/8"	40-75	20	60
5/8" x 8-1/2"	2658812	4"	2858812	4"	2758812*	4"	275881S*	4"	2558812	4"	5/8"	O	5-1/8"	40-75	20	60
5/8" x 10"	2658100	2"	2858100	2"	2758100*	2"	275810S*	2"	2558100*	4"	5/8"	R	6 5/8"	40-75	20	60
3/4" x 4-1/4"	2634414	2-1/4"	2834414	2-1/4"	2734414	2-1/4"	273441S*	2-1/4"	2534414	2-3/8"	3/4"	F	1/8"	100-200	25	75
3/4" x 4-3/4"	2634434	2-3/4"	2834434	2-3/4"	2734434	2-3/4"	273443S	2-3/4"	2534434	2-7/8"	3/4"	G	5/8"	100-200	25	75
3/4" x 5-1/2"	2634512	3-1/2"	2834512	3-1/2"	2734512	3-1/2"	273451S	3-1/2"	2534512	3-5/8"	3/4"	I	1-3/8"	100-200	20	60
3/4" x 6-1/4"	2634614	4"	2834614	4"	2734614*	4"	273461S*	4"	2534614*	4-1/4"	3/4"	J	2-1/8"	100-200	20	60
3/4" x 7"	2634700	4"	2834700	4"	2734700	4"	273470S*	4"	2534700	4"	3/4"	L	2-7/8"	100-200	15	45
3/4" x 8-1/2"	2634812	4"	2834812	4"	2734812	4"	273481S*	4"	2534812*	4"	3/4"	O	4-3/8"	100-200	15	45
3/4" x 10"	2634100	2-1/4"	2834100	2 1/4"	2734100	2 1/4"	273410S*	2 1/4"	2534100	4"	3/4"	R	5-7/8"	100-200	15	45
3/4" x 12"	263412T	2-1/4"	283412T	2 1/4"	2734120*	2 1/4"	273412S*	2 1/4"	2534120*	4"	3/4"	T	7-7/8"	100-200	10	30
7/8" x 6"	2678600	2-1/8"	2878600	2 1/8"	2778600*	2-1/8"	277860S*	2-1/8"	2578600	2-1/4"	7/8"	J	1-1/8"	125-225	10	30
7/8" x 8"	2678800	2-1/8"	2878800	2 1/8"	2778800*	4-3/4"	277880S*	2-1/8"	2578800	2-1/4"	7/8"	N	3-1/8"	125-225	10	30
7/8" x 10"	2678100	2-1/8"	2878100	2 1/8"	2778100*	2-1/8"	277810S*	2-1/8"	2578100	2-1/4"	7/8"	R	5-1/8"	125-225	10	30
1" x 6"	2616000	2-1/4"	2816000	2 1/4"	2716000	2-3/8"	271600S*	2 1/4"	2516000	2-1/4"	1"	J	1/2"	150-250	10	30
1" x 9"	2619000	2-1/4"	2819000	2 1/4"	2719000	4-3/8"	271900S*	2 1/4"	2519000	2-1/4"	1"	P	3-1/2"	150-250	5	15
1" x 12"	2611200	2-1/4"	2811200	2 1/4"	2711200	4-3/8"	271120S*	2 1/4"	2511200*	2-1/4"	1"	T	6-1/2"	150-250	5	15
1-1/4" x 9"	2611490	2-3/4"	2811490	2 3/4"	2711490*	3-1/4"	271149S*	4"	2511490	3-1/4"	1-1/4"	P	1-1/4"	200-350	5	15
1-1/4" x 12"	2611412	2-3/4"	2811412	2 3/4"	2711412*	3-1/4"	271141S*	3-1/4"	2511412	3-1/4"	1-1/4"	T	4-1/4"	200-350	4	12

MADE IN THE USA ANCHORING SYSTEMS

FORWAY

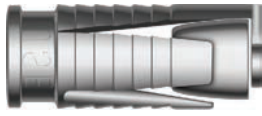

AVAILABLE MATERIALS

- Zinc diecast alloy

FEATURES/ADVANTAGES

- Medium to heavy loads
- Can be used in dead, variable, or vibratory conditions in all types of solid or hollow masonry materials
- Four-way expansion assures positive anchoring even under adverse drilling conditions

APPROVALS/LISTINGS

- G.S.A. Spec A-A-55614

Ultimate Loads in Lbs.

ORDER DETAIL

Order Code	Bolt Dia.	Hole Dia.	Shield Length	Tension*	Shear*	Tension Block	Box Qty.	Master Qty.
1104000	1/4"-20	1/2"	1-1/4"	2,320	2,100	1,925	100	800
1105000	5/16"-18	9/16"	1-1/2"	2,600	3,300	2,100	100	500
1106000	3/8"-16	11/16"	1-3/4"	3,640	3,850	2,440	50	400
1108000	1/2"-13	7/8"	2-1/4"	5,100	8,100	3,050	50	150
1110000	5/8"-11	1-1/8"	2-5/8"	5,820	14,170	N.A.	50	100
1112000	3/4"-10	1-1/4"	3-1/8"	9,850	15,300	N.A.	25	50

* Tested in 3000 P.S.I. Concrete

INSTALLATION

- 1 Drill hole to at least shield length.
- 2 Clean hole of debris.
- 3 Place the Forway in the hole.
- 4 Position equipment. Insert machine bolt through equipment into shield.
- 5 Tighten.

For hanger rod installation

- 1 Thread a hex nut onto the hanger rod, add a flat washer, then screw the Forway against the washer.
- 2 Place the Forway in the hole.
- 3 Expand the Forway by tightening the hex nut against the surface of the base material.

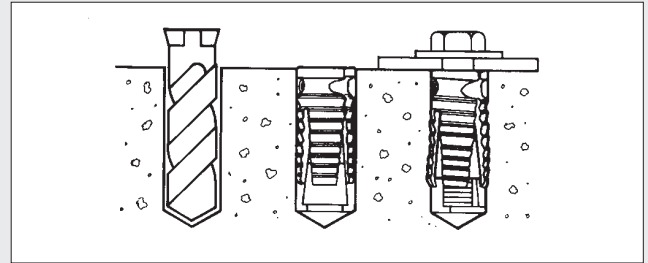

TAPER BOLT®

AVAILABLE MATERIALS

- Grade 5, zinc plated
- Other metals and finishes are available by special quote
- Eye bolt version available by special quote

FEATURES/ADVANTAGES

- Required hole diameter equals anchor diameter
- Variation in hole size can be accommodated by turning the expander nut
- Equipment may be removed and replaced. The bolt is simply re-inserted and torqued to obtain original holding power (the nut stays in the hole)
- Bolt can be removed and re-used with a new nut after cleaning and lubricating the threads
- Strength - the highest shear strength of any expansion anchor
- Withstands vibratory loads
- Works in a bottomless hole

APPROVALS/LISTINGS

- Tested by Pittsburgh Testing Laboratory PG-2170
- Contact customer service for approvals/ listings for state D.O.T.'s

CONSIDERATIONS

- Head clearance critical to anchor effectiveness

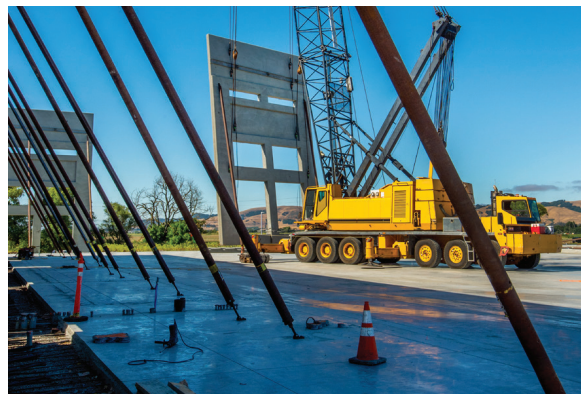

Ultimate Tensile & Shear Loads in Lbs.

ORDER DETAIL	Order Code Grade 5 Hex Hd. Bolt	Anchor Dia. & Length	Hole Dia.	Min. Embed.	Required Torque to set	Head Size	Required Head Clearance	3000 P.S.I.		5000 P.S.I.		Box Qty.	Master Qty.
								Tension (lbs.)	Shear (lbs.)	Tension (lbs.)	Shear (lbs.)		
	3420000	3/8" x 2-1/4"	3/8"	1-7/8"	40	9/16"	3/16"	4,030	7,177	4,987	8,567	50	400
	3421000	3/8" x 2-5/8"	3/8"	1-7/8"	40	9/16"	3/16"	4,030	7,177	4,987	8,567	50	400
	3422000	3/8" x 3"	3/8"	1-7/8"	40	9/16"	3/16"	4,030	7,177	4,987	8,567	50	400
	3423000	3/8" x 4"	3/8"	1-7/8"	40	9/16"	3/16"	4,030	7,177	4,987	8,567	50	400
	3430000	1/2" x 2-7/8"	1/2"	2-3/8"	90	3/4"	1/4"	8,165	12,177	9,346	15,217	25	200
	3431000	1/2" x 4"	1/2"	2-3/8"	90	3/4"	1/4"	8,165	12,177	9,346	15,217	25	200
	3432000	1/2" x 5"	1/2"	2-3/8"	90	3/4"	1/4"	8,165	12,177	9,346	15,217	20	100
	3440000	5/8" x 3-1/2"	5/8"	2-7/8"	125	15/16"	5/16"	9,990	17,030	10,470	17,257	20	75
	3441000	5/8" x 4-1/2"	5/8"	2-7/8"	125	15/16"	5/16"	9,990	17,030	10,470	17,257	25	75
	3442000	5/8" x 6"	5/8"	2-7/8"	125	15/16"	5/16"	9,990	17,030	10,470	17,257	25	75
	3443000	5/8" x 7"	5/8"	2-7/8"	125	15/16"	5/16"	9,990	17,030	10,470	17,257	25	75
	3450000	3/4" x 4-1/8"	3/4"	3-3/8"	250	1-1/8"	7/16"	11,906	27,916	17,073	28,110	20	60
	3451000	3/4" x 5-1/2"	3/4"	3-3/8"	250	1-1/8"	7/16"	11,906	27,916	17,073	28,110	20	60
	3452000	3/4" x 7"	3/4"	3-3/8"	250	1-1/8"	7/16"	11,906	27,916	17,073	28,110	15	45
	3453000	3/4" x 8"	3/4"	3-3/8"	250	1-1/8"	7/16"	11,906	27,916	17,073	28,110	15	45
	3460000	1" x 5-5/8"	1"	4-5/8"	550	1-1/2"	5/8"	28,263	36,257	30,817	38,487	10	30
	3461000	1" x 6-3/4"	1"	4-5/8"	550	1-1/2"	5/8"	28,263	36,257	30,817	38,487	10	30
	3462000	1" x 7-1/4"	1"	4-5/8"	550	1-1/2"	5/8"	28,263	36,257	30,817	38,487	10	20

ADDITIONAL NUTS

Order Code	Size	Box Qty.	Master Qty.
3420200	3/8"	100	3,000
3430200	1/2"	50	600
3440200	5/8"	50	400
3450200	3/4"	50	400
3460200	1"	10	120

INSTALLATION

- 1 Drill hole the same diameter as the Taper-Bolt using fixture as a template.
- 2 Clean hole of debris.
- 3 Drive Taper-Bolt into place leaving recommended head clearance. If hole is oversized simply remove and pre-expand the expander nut to fit hole.
- 4 Tighten Taper-Bolt to recommended torque.
- 5 For big jobs, set Taper-Bolt with an impact wrench. This method offers speed, consistency and greater installer productivity.

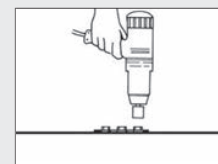
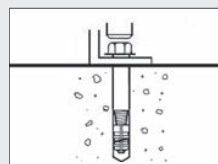
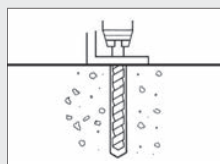

TAP-IT®**TAP-IT® NYLON WASHER****AVAILABLE MATERIALS**

Nylon Tap-It body with:

- Carbon steel nail, zinc plated
- Aluminum nail, bulk only
- Zinc plated nail available in bulk pack
- High strength nylon

FEATURES/ADVANTAGES

- Light to medium loads under dead, variable, or vibratory conditions in solid or hollow base materials

APPROVALS/LISTINGS

- G.S.A. Spec A-A-1925A, CID Type 3

FEATURES/ADVANTAGES

- Acts as a bearing surface when anchoring through soft material into concrete or other suitable base materials

APPROVALS/LISTINGS

- G.S.A. Spec A-A-1925A, CID Type 3

**ORDER DETAIL**

Order Code	Hole I.D.	Washer O.D.	Box Qty.
5901000	1/4"	1-1/2"	100
5903000	pilot hole	1-1/2"	100

INSTALLATION

- 1 Drill hole same diameter as "Tap-It" shell.
- 2 Clean hole of debris.
- 3 Insert shell through washer and into object to be fastened, then into the hole.
- 4 Tap nail until flush with nylon head.

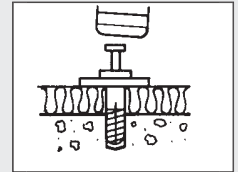
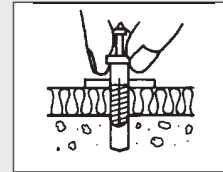
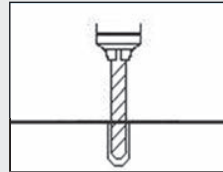
**ORDER DETAIL**

Ultimate Tensile & Shear Loads in Lbs.
Concrete Strength (P.S.I.)
3000 P.S.I.

Order Code	Hole/Anchor Diameter / Length	Head Style Diameter	Minimum Hole Depth	Minimum Embedment	Tension	Shear	Box Qty.	Master Qty.
Round Head								
4630000	3/16" x 1"	RND-3/8"	1-1/4"	3/4"	283	713	100	1200
* 4730000	3/16" x 1-1/2"	RND-3/8"	1-3/4"	1"	335	887	100	1200
5630000	1/4" x 1"	RND-7/16"	1-1/4"	3/4"	261	884	100	1200
5730000	1/4" x 1-1/2"	RND-7/16"	1-3/4"	1"	320	951	100	1200
5830000	1/4" x 2"	RND-7/16"	2-1/4"	1"	325	972	100	300
Mushroom Head								
4460000	3/16" x 3/4"	MUSH-9/16"	1"	5/8"	283	793	100	1200
4660000	3/16" x 1"	MUSH-9/16"	1-1/4"	3/4"	370	687	100	1200
5460000	1/4" x 3/4"	MUSH-9/16"	1"	5/8"	261	884	100	1200
5660000	1/4" x 1"	MUSH-9/16"	1-1/4"	3/4"	261	884	100	1200
5760000	1/4" x 1-1/2"	MUSH-9/16"	1-3/4"	1"	320	951	100	800
5860000	1/4" x 2"	MUSH-9/16"	2-1/4"	1"	253	590	100	500
* 5160000	1/4" x 3"	MUSH-11/16"	3-1/4"	1-1/4"	261	884	100	500
* 5260000	1/4" x 4"	MUSH-11/16"	4-1/4"	1-1/4"	261	884	100	300

*Unassembled

INSTALLATION

- 1 Drill hole same diameter as "Tap-It" shell and slightly deeper than fastener length in solid material.
- 2 Clean hole of debris.
- 3 Insert shell through object to be fastened and into the hole.
- 4 Tap nail until flush with nylon head.

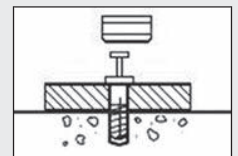
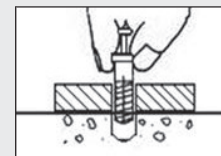
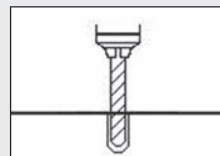

UNI-TAP

AVAILABLE MATERIALS

- High strength nylon

FEATURES/ADVANTAGES

- Light to medium loads under dead, variable or vibratory conditions, in solid or hollow masonry

APPROVALS/LISTINGS

- G.S.A. Spec A-A-55614
- Contact customer service for approvals

CONSIDERATIONS

- Drill recommended hole diameter

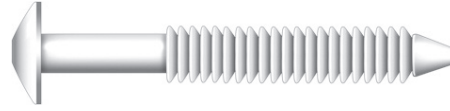

ORDER DETAIL

Order Code	Size	HOLE DIAMETER		Head Diameter	Grip Range	Tension Hollow Wall	Shear Hollow Material	Tension Cement Block	Head Style	Box Qty.	Master Qty.
		Masonry	Wood / Metal								
6460000	9/32" x 1"	1/4"	9/32"	5/8"	3/16-1/2"	130	250	150	TRUSS	100	1200
6660000	9/32" x 1-5/8"	1/4"	9/32"	5/8"	3/8-1 1/8"	130	253	158	TRUSS	100	800
6760000	9/32" x 2-1/8"	1/4"	9/32"	5/8"	7/8-1 5/8"	130	274	154	TRUSS	100	800
6860000	9/32" x 2-5/8"	1/4"	9/32"	5/8"	1 3/8-2 1/8"	130	238	163	TRUSS	100	500
6960000	9/32" x 3-1/8"	1/4"	9/32"	5/8"	1 7/8-2 5/8"	130	228	150	TRUSS	100	500

INSTALLATION

- 1 Drill hole slightly deeper than fastener length.
- 2 Clean hole of debris.
- 3 Tap "Uni-Tap" into place through material to be fastened.

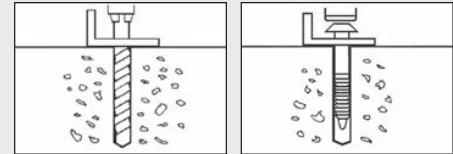



HEAVY DUTY

ANCHORING SYSTEMS

SZ HIGH LOAD ANCHOR

AVAILABLE MATERIALS

- High strength steel
- Flat head style available by special order

FEATURES/ADVANTAGES

- ACI 318 category 1 anchor for cracked or uncracked concrete
- Required hole diameter equals anchor diameter
- Equipment can be removed. The bolt and sleeve can be removed for a flush surface. The expansion sleeve and cone remain in the hole.
- Exceptional strength coupled with the ability to resist seismic loads.
- Category A-F
- Metric dimensions for international use.
- Collapsible sleeve allows for secure clamping force.
- Embedment depth is marked on each anchor for easy installation.
- Multiple head styles available.

APPROVALS/LISTINGS

- European Technical Approval ETA-02/0030
- Tested by the University of Stuttgart
- ICC ESR-3173 (M12-M28 carbon steel and M12-M24 316 stainless steel)
- ACI 318 category 1

CONSIDERATIONS

- Do not use in brick or block
- Must be installed with a metric drill bit



ORDER DETAIL

Anchor Diameter & Length

Description	SZ-S (Bolt Version)	SZ-B (Stud Version)	Drill Hole Dia. x Depth (mm)	Min. Embed.(mm)	SZ-S (mm)	SZ-B (mm)	Thread Diameter (mm)	Maximum Thickness Fastened (mm)	Required Torque to Set (ft. lbs.)	Box Qty.
SZ 10-0	M14005301	M16005301	10 x 65	60	10 x 65	10 x 67	M6	0	11	100
SZ 10-10	M14010301	M16010301	10 x 65	60	10 x 75	10 x 77	M6	10	11	50
SZ 10-30	M14025301	M16025301	10 x 65	60	10 x 95	10 x 97	M6	30	11	50
SZ 10-50	M14030301	M16030301	10 x 65	60	10 x 115	10 x 117	M6	50	11	50
SZ 10-100		M16045301	10 x 65	60		10 x 167	M6	100	11	25
SZ 12-0	M14105301	M16105301	12 x 80	70	12 x 77	12 x 80	M8	0	22	50
SZ 12-10	M14110301	M16110301	12 x 80	70	12 x 87	12 x 90	M8	10	22	50
SZ 12-30	M14125301	M16125301	12 x 80	70	12 x 107	12 x 110	M8	30	22	50
SZ 12-50	M14130301	M16130301	12 x 80	70	12 x 127	12 x 130	M8	50	22	25
SZ 12-100	-	M16145301	12 x 80	70		12 x 180	M8	100	22	25
SZ 15-0	M14205301	M16205301	15 x 95	85	15 x 93	15 x 96	M10	0	37	25
SZ15-15	M14215301	M16215301	15 x 95	85	15 x 108	15 x 111	M10	15	37	25
SZ 15-25	M14220301	M16220301	15 x 95	85	15 x 118	15 x 121	M10	25	37	25
SZ 15-45	M14225301	M16225301	15 x 95	85	15 x 138	15 x 141	M10	45	37	25
SZ 15-95	M14240301	M16240301	15 x 95	85	15 x 188	15 x 191	M10	95	37	25
SZ 18-0	M14305301	M16305301	18 x 105	95	18 x 107	18 x 112	M12	0	59	20
SZ 18-10	M14310301	M16310301	18 x 105	95	18 x 117	18 x 122	M12	10	59	20
SZ 18-20	M14315301	M16315301	18 x 105	95	18 x 127	18 x 132	M12	20	59	20
SZ 18-40	M14325301	M16325301	18 x 105	95	18 x 147	18 x 152	M12	40	59	20
SZ 18-70	M14335301	M16335301	18 x 105	95	18 x 177	18 x 182	M12	70	59	20
SZ 18-100		M16340301	18 x 105	95		18 x 212	M12	100	59	10
SZ 24-0	M14505301	M16505301	24 x 130	120	24 x 132	24 x 137	M16	0	118	10
SZ 24-20	M14515301	M16515301	24 x 130	120	24 x 152	24 x 157	M16	20	118	10
SZ 24- 50	M14525301	M16525301	24 x 130	120	24 x 182	24 x 187	M16	50	118	10
SZ 24-100		M16530301	24 x 130	120		24 x 237	M16	100	118	5
SZ 24-0 L	M14555301	M16555301	24 x 130	135	24 x 150	24 x 152	M16	0	118	10
SZ 24-30 L	M14565301	M16565301	24 x 130	135	24 x 180	24 x 182	M16	30	118	10
SZ 24-50 L	M14575301	M16575301	24 x 130	135	24 x 200	24 x 202	M16	50	118	10
SZ 28-10	M14610301	M16610301	28 x 160	150	28 x 172	28 x 181	M20	10	207	10
SZ 28-30	M14615301	M16615301	28 x 160	150	28 x 192	28 x 201	M20	30	207	10
SZ 28-60	M14625301	M16625301	28 x 160	150	28 x 222	28 x 231	M20	60	207	5
SZ 28-100	M14630301	M16630301	28 x 160	150	28 x 262	28 x 271	M20	100	207	5

Additional sizes available upon request. To convert to inches, divide millimeters by 25.4.

Load & Performance Data

	Conc.(psi)	Symbol	Units	SZ10 M6	SZ12 M8	SZ15 M10	SZ18 M12	SZ24 M16	SZ24L M16L	SZ28 M20
Cracked Concrete										
Avg. ultimate load, tension	4,000	N_{fn}	lbs	3,765	5,780	7,717	9,988	14,057	19,227	21,444
Avg. ultimate load, shear	SZ-S	V_n	lbs	5,620	8,497	12,510	18,849	38,920	38,920	44,623
Avg. ultimate load, shear	SZ-B	V_n	lbs	5,125	7,171	10,363	19,041	26,212	26,212	37,317
Allowable Tension Loads ¹	2,500	N_{allow}	lbs	484	1,162	1,549	2,206	3,083	3,802	4,308
	4,000	N_{allow}	lbs	612	1,469	1,959	2,790	3,900	4,809	5,450
	6,000	N_{allow}	lbs	750	1,799	2,399	3,417	4,776	5,890	6,675
	8,500	N_{allow}	lbs	892	2,142	2,856	4,068	5,685	7,010	7,944
Uncracked Concrete										
Allowable Tension Loads ¹	2,500	N_{allow}	lbs	1,539	1,936	2,604	3,114	4,352	5,367	6,082
	4,000	N_{allow}	lbs	1,927	2,449	3,294	3,939	5,505	6,789	7,694
	6,000	N_{allow}	lbs	1,927	2,999	4,034	4,825	6,743	8,315	9,423
	8,500	N_{allow}	lbs	1,927	3,493	4,801	5,742	8,025	9,897	11,216
Cracked and Uncracked Concrete										
Allowable Shear Loads ¹	2,500	V_{allow}	lbs	1,670	2,557	3,778	4,751	6,640	8,189	9,280
	4,000	V_{allow}	lbs	1,670	2,557	3,778	6,010	8,399	9,519	11,738
	>6,000	V_{allow}	lbs	1,670	2,557	3,778	6,597	9,519	9,519	12,734

Spacing & Edge Distance

Effective Anchorage Depth	h_{ef}	in	1.97	2.36	2.80	3.15	3.94	4.53	4.92
		(mm)	(50)	(60)	(71)	(80)	(100)	(115)	(125)
Critical Edge Distance	C_{ec}	in	2.95	3.54	4.89	4.72	5.91	6.79	7.38
		(mm)	(75)	(90)	(107)	(120)	(150)	(173)	(188)
Minimum Spacing for Edge Distance C	S_{min}/C	in	1.97/3.15	2.36/3.94	2.76/4.72	3.15/6.30	3.94/7.09	3.94/7.09	4.92/11.81
		(mm)	(50/80)	(60/100)	(70/120)	(80/160)	(100/180)	(100/180)	(125/300)
Minimum Edge Distance for Spacing S	C_{min}/S	in	1.57/3.94	2.36/4.72	2.76/6.89	3.15/7.87	3.94/8.66	7.34/8.66	7.09/21.26
		(mm)	(50/100)	(60/120)	(70/175)	(80/200)	(100/220)	(100/220)	(180/540)
Minimum thickness of concrete slab	h_{min}	in	3.94	4.72	5.51	6.30	7.87	9.06	9.84
		(mm)	(100)	(120)	(140)	(160)	(200)	(230)	(250)

Installation Parameters

Drilled hole diameter	d_o	in	.39	.47	.59	.71	.94	.94	1.10
		(mm)	(10)	(12)	(15)	(18)	(24)	(24)	(28)
Diameter of clearance hole	d_c	in	.47	.55	.67	.79	1.02	1.02	1.22
		(mm)	(12)	(14)	(17)	(20)	(26)	(26)	(31)
Depth of drilled hole	h_o	in	2.25	3.15	3.74	4.13	5.12	5.71	6.30
		(mm)	(65)	(80)	(95)	(105)	(130)	(145)	(160)
Installation Torque	T_{inst}	ft-lbs	11	22	37	59	118	118	207
Wrench size	WS	(mm)	(10)	(13)	(17)	(19)	(24)	(24)	(30)

1) A safety factor of 1.48 was used to calculate the allowable loads. This is based on a load combination of 30% dead loads and 70% live loads.

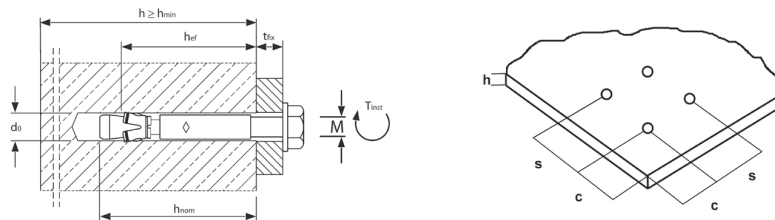
**INSTALLATION**

- 1 Drill hole to recommended size and depth.
- 2 Remove dust, rubble from the hole with compressed air.
- 3 Using a hammer, tap the anchor through the material to be fastened until the anchor is firmly seated.
- 4 Tighten the anchor to the specified torque.

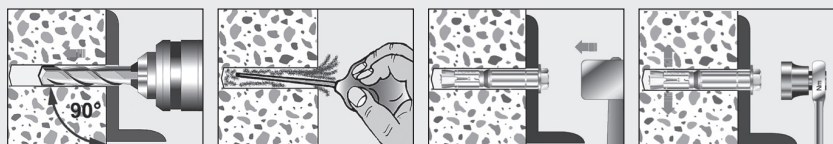

The background features a series of thin, parallel, light-colored diagonal lines that create a sense of depth and movement. A solid red vertical bar is positioned on the right side of the image. The text is centered in the lower half of the frame.

MEDIUM DUTY

ANCHORING SYSTEMS

SUP-R DROP

AVAILABLE MATERIALS

- Carbon steel, zinc plated
- 304 stainless steel
- 316 stainless steel



FEATURES/ADVANTAGES

- Ideal for flush-mounting applications
- Preassembled for ease of installation
- Female threads accept standard UNC bolts or threaded rods (1/4" to 3/4")
- Slotted body is precision-matched to tapered internal plug for uniform expansion
- Knurled body increases friction connection between anchor and wall of hole

APPROVALS/LISTINGS

- G.S.A. Spec A-A-55614
- UL listed 3/8"-3/4"
- FM 3/8" - 1/2" & 3/4"
- Contact customer service for approvals



CONSIDERATIONS

- Dead load only
- Hole depth must be equal to anchor length
- Do not over torque

ORDER DETAIL

Order Code C-Steel	Order Code 304 Stainless	Order Code 316 Stainless	UNC Bolt Size	Minimum Embedment	Max Torque (ft. lbs.)	Hole	2000 P.S.I.		4000 P.S.I.		C-Steel 304 S.S. Box Qty.	C-Steel 304 S.S. Master Qty.	316 S.S. Box Qty.	316 S.S. Master Qty.
							Tension (lbs.)	Shear (lbs.)	Tension (lbs.)	Shear (lbs.)				
1314000	1314SS0	1314SS6	1/4"	1"	5	3/8"	2,050	1,321	2,104	1,321	100	1,000	25	300
1338000	1338SS0	1338SS6	3/8"	1-9/16"	10	1/2"	3,957	3,714	4,824	3,714	50	500	25	300
1312000	1312SS0	1312SS6	1/2"	2"	20	5/8"	5,312	5,854	7,398	5,854	50	250	25	300
1358000	1358SS0	1358SS6	5/8"	2-1/2"	40	7/8"	7,398	8,754	7,966	8,754	25	125	25	125
1334000	1334SS0	1334SS6	3/4"	3-3/16"	80	1"	12,300	11,627	16,019	11,627	10	50	25	75

SUP-R DROP SETTING TOOLS

Order Code C-Steel	Description
1314700	1/4" Drop-In Setting tool
1338700	3/8" Drop-In Setting tool
1312700	1/2" Drop-In Setting tool
1358700	5/8" Drop-In Setting tool
1334700	3/4" Drop-In Setting tool

INSTALLATION

- 1 Drill hole same length as anchor. Do not use core bits. Maintain accurate hole size.
- 2 Clean hole of debris.
- 3 Drop in anchor, slotted end first.
- 4 To set, drive setting tool into anchor until shoulder of tool is flush with top of anchor.
- 5 Select proper bolt length.

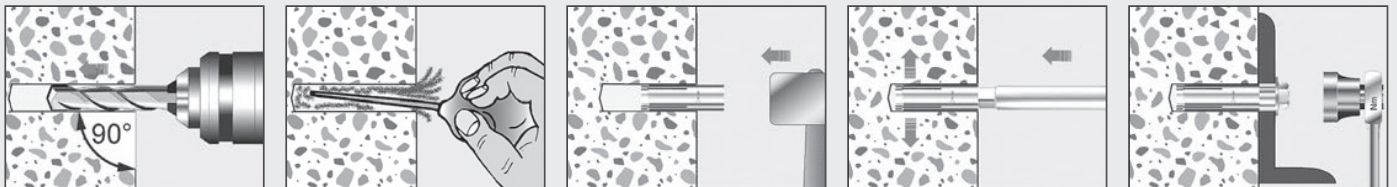

COIL THREAD **Sup-r** DROP

AVAILABLE MATERIALS

- Carbon steel, zinc plated

FEATURES/ADVANTAGES

- Ideal for form work and tilt-up bracing
- Accepts 1/2" or 3/4" standard coil thread rod or coil thread bolts
- Preassembled for ease of installation
- Slotted body is precision-matched to tapered internal plug for uniform expansion
- Knurled body increases friction connection between anchor and wall of hole



APPROVALS/LISTINGS

- G.S.A. Spec A-A-55614
- Contact customer service for approvals

CONSIDERATIONS

- Dead load only
- Hole depth must be equal to anchor length
- Do not over torque

ORDER DETAIL

Order Code	Bolt Diameter	Hole Diameter	Minimum Embedment	Max Torque (ft. lbs.)	2000 P.S.I.		4000 P.S.I.		Box Qty.	Master Qty.
					Tension (lbs.)	Shear (lbs.)	Tension (lbs.)	Shear (lbs.)		
1312CTO	1/2"	5/8"	2"	20	5,312	5,854	7,398	5,854	50	250
1334CTO	3/4"	1"	3-3/16"	80	12,300	11,627	16,019	11,627	10	50

Sup-r SHORTY & LIPPED **Sup-r** DROP

FEATURES/ADVANTAGES

- Lip ensures proper anchor setting even in hollow based material
- Female threads accept standard UNC bolts or threaded rods



APPROVALS/LISTINGS

- G.S.A. Spec A-A-55614

ORDER DETAIL

Order Code C-Steel	Order Code 304 Stainless	Order Code 316 Stainless	UNC Bolt Size	Minimum Embedment	Max Torque (ft. lbs.)	Hole Diameter	2000 P.S.I.		4000 P.S.I.		C-Steel Box Qty.	C-Steel Master Qty.
							Shear (lbs.)	Tension (lbs.)	Shear (lbs.)	Tension (lbs.)		
131200L	—	—	1/2"	2"	20	5/8"	5,312	7,398	5,854	—	50	250
133800L	—	—	3/8"	1-9/16"	10	1/2"	3,957	4,824	3,714	—	50	400
13380SH	—	—	3/8"	3/4"	5	1/2"	2,083	—	3,714	—	100	800

INSTALLATION

- 1 Drill hole same length as anchor. Do not use core bits. Maintain accurate hole diameter.
- 2 Clean hole of debris.
- 3 Drop in anchor, slotted end first.
- 4 To set, drive setting tool into anchor until shoulder of tool is flush with top of anchor.
- 5 Select appropriate coil thread rod or coil bolt.

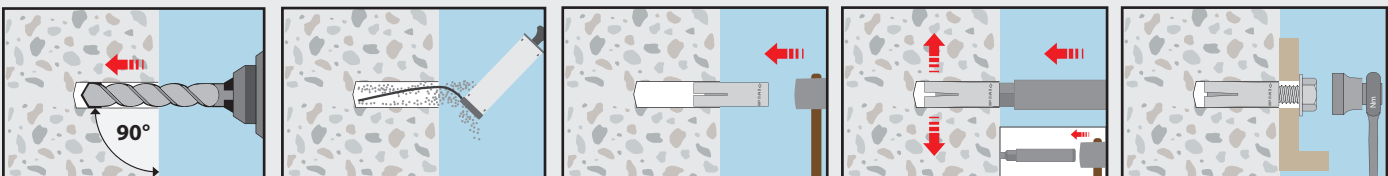

Sup-r BOLT

AVAILABLE MATERIALS

- Carbon Steel, zinc plated
- 316 Stainless Steel

FEATURES/ADVANTAGES

- Required hole diameter equals anchor diameter
- Designed for standard ANSI tolerance drill bits
- Hardened threads for tapping high strength concrete
- Anti-rotation teeth on underside of hex washer head lock against the fixture
- Can be installed closer to the edge than traditional expansion anchors
- Fast installation with powered impact wrench
- Diameter, length and identifying marking stamped on head of each anchor
- One-piece, finished head design
- Equipment can be removed.
- Able to resist seismic loads.

APPROVALS/LISTINGS

- ICC-ES ESR 4347
- ACI 318 category 1 for cracked concrete
- ICC ESR-5359 - Masonry

CONSIDERATIONS

- Do not use in brick or hollow block
- Do not reuse

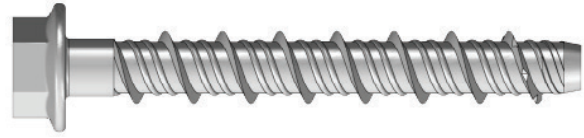

ORDER DETAIL

Anchor Dimensions	Order Code	Drill Hole Dia. x Depth (in)	Min. Embed.(in)	Maximum Thickness Fastened (in)	Required Torque to Set (ft. lbs.)	Box Qty.
1/4" X 1-3/4"	4114134	1/4 x 2	1-5/8	1/8	15	100
1/4" X 2-1/4"	4114214	1/4 x 2-3/8	1-5/8	5/8	15	100
1/4" X 3"	4114300	1/4 x 2-3/8	1-5/8	1-5/8	15	100
1/4" X 4"	4114400	1/4 x 2-3/8	1-5/8	2-3/8	15	100
3/8" X 1-3/4"	4138134	3/8 x 2-3/4	2-1/2	1/4	35	50
3/8" X 2-1/2"	4138212	3/8 x 2-3/4	2-1/2	1/4	35	50
3/8" x 3"	4138300	3/8 x 2-3/4	2-1/2	1/2	35	50
3/8" x 4"	4138400	3/8 x 2-3/4	2-1/2	1-1/2	35	50
3/8" x 5"	4138500	3/8 x 2-3/4	2-1/2	2-1/2	35	50
3/8" x 6"	4138600	3/8 x 2-3/4	2-1/2	3-1/2	35	50
1/2" x 4"	4112400	1/2 x 3-3/8	3	1	45	25
1/2" x 5"	4112500	1/2 x 3-3/8	3	2	45	25
1/2" x 6"	4112600	1/2 x 3-3/8	3	3	45	25
1/2" X 8"	4112800	1/2 x 3-3/8	3	5	45	25
5/8" X 3"	4158300	5/8 x 3-5/8	3-1/4	5/8	85	25
5/8" x 4"	4158400	5/8 x 3-5/8	3-1/4	3/4	85	25
5/8" x 5"	4158500	5/8 x 3-5/8	3-1/4	1-3/4	85	25
5/8" x 6"	4158600	5/8 x 3-5/8	3-1/4	2-3/4	85	20
5/8" x 8"	4158800	5/8 x 3-5/8	3-1/4	4-3/4	85	20
3/4" x 4"	4134400	3/4 x 4-3/8	4	1/4	115	15
3/4" x 5"	4134500	3/4 x 4-3/8	4	1	115	15
3/4" x 6"	4134600	3/4 x 4-3/8	4	2	115	15
3/4" x 7"	4134700	3/4 x 4-3/8	4	3	115	15
3/4" x 10"	4134100	3/4 x 4-3/8	4	6	115	5

Sup-r BOLT 316 SS

ORDER DETAIL

Anchor Dimensions	Order Code	Drill Hole Dia. x Depth (in)	Min. Embed.(in)	Maximum Thickness Fastened (in)	Required Torque to Set (ft. lbs.)	Box Qty.
1/4" X 1-3/4"	4314134	1/4 x 2-3/8	2	1/8	10	100
1/4" X 2"	4314214	1/4 x 2-3/8	2	5/8	10	100
1/4" X 3"	4314300	1/4 x 2-3/8	2	1-5/8	10	100
1/4" X 4"	4314400	1/4 x 2-3/8	2	2-3/8	10	100
3/8" X 1-3/4"	4338134	3/8 x 3	2-3/4	1/4	35	50
3/8" X 2-1/2"	4338212	3/8 x 3	2-3/4	1/4	35	50
3/8" X 3"	4338300	3/8 x 3	2-3/4	1/2	35	50
3/8" X 4"	4338400	3/8 x 3	2-3/4	1-1/2	35	50
3/8" X 5"	4338500	3/8 x 3	2-3/4	2-1/2	35	50
3/8" X 6"	4338600	3/8 x 3	2-3/4	3-1/2	35	50
1/2" X 3"	4312300	1/2 x 3-3/8	3	1/4	35	25
1/2" X 4"	4312400	1/2 x 3-3/8	3	1	35	25
1/2" X 5"	4312500	1/2 x 3-3/8	3	2	35	25
1/2" X 6"	4312600	1/2 x 3-3/8	3	3	35	25
1/2" X 8"	4312800	1/2 x 3-3/8	3	5	35	25

* Catalog numbers denote sizes which are less than the minimum standard anchor length for strength Design. Anchors not long enough to meet the minimum nominal embedments published for strength design are outside the scope of ICC-ES ESR-4747 & ICC-ES ESR-5359.

Load & Performance Data	Conc.(psi)	Symbol	Units	1/4"	3/8"	1/2"	5/8"	3/4"			
Embedment depth		h_{nom}	in	2-1/2	3-1/4	3	4-1/4	3-1/4	5	4	6-1/4
Cracked Concrete											
Avg. ultimate load, tension	4,000	$N_{u,cr}$	lbs	2,705	4,225	4,077	6,358	3,898	8,122	5,503	11,626
Avg. ultimate load, shear	4,000	$V_{u,cr}$	lbs	1,894	2,957	3,054	6,091	2,729	8,278	7,704	9,255
Allowable loads, tension ¹	2,500	$N_{allow,cr}$	lbs	939	1,467	1,416	2,207	1,353	2,820	1,911	4,037
	4,000	$N_{allow,cr}$	lbs	1,188	1,855	1,790	2,792	1,712	3,567	2,417	5,106
	6,000	$N_{allow,cr}$	lbs	1,455	2,272	2,193	3,420	2,097	4,369	2,960	6,254
	8,500	$N_{allow,cr}$	lbs	1,732	2,705	2,610	4,070	2,496	5,200	3,523	7,443
Uncracked Concrete											
Allowable loads, tension ¹	2,500	$N_{allow,uncr}$	lbs	1,326	2,330	1,416	3,116	1,911	3,981	2,698	5,699
	4,000	$N_{allow,uncr}$	lbs	1,677	2,947	1,692	3,942	2,417	5,036	3,412	7,209
	6,000	$N_{allow,uncr}$	lbs	2,054	3,609	1,974	4,828	2,960	6,168	4,179	8,829
	8,500	$N_{allow,uncr}$	lbs	2,445	4,296	2,254	5,746	3,523	7,341	4,974	10,508
Allowable loads, tension - light weight ¹	3,000			872		930		1,256		1,773	
Cracked and Uncracked Concrete											
Allowable loads, shear ¹	2,500	V_{allow}	lbs	1,428	1,428	2,098	4,116	5,594	5,594	5,810	6,253
	>4,000	V_{allow}	lbs	1,805	1,806	2,653	4,116	5,594	5,594	6,253	6,253
Allowable loads, shear - light weight ¹	3,000	V_{allow}	lbs	563		827		811		2,291	

Spacing & Edge Distance

Effective Anchorage Depth	h_{ef}	in	1.85	2.49	2.21	3.27	2.36	3.85	2.97	4.89
Critical Edge Distance	C_{ac}	in	4	5	4-1/2	5	3-3/4	7	4-1/2	8
Minimum Spacing	S_{min}	in	3	3	3	3	4	4	4	4
Minimum Edge Distance	C_{min}	in	1-1/2	1-1/2	1-3/4	1-3/4	1-3/4	1-3/4	1-3/4	1-3/4
Minimum thickness of concrete slab	h_{min}	in	4	4-3/4	4-3/4	6-3/4	5	7	6	8-1/8

Installation Parameters

Drilled hole diameter	d_o	in	3/8	3/8	1/2	1/2	5/8	5/8	3/4	3/4
Diameter of clearance hole	d_c	in	1/2	1/2	5/8	5/8	3/4	3/4	7/8	7/8
Depth of drilled hole	h_o	in	2-3/4	3-1/2	3-3/8	4-5/8	3-5/8	5-3/8	4-3/8	6-5/8
Installation Torque	T_{inst}	ft-lbs	35	50	45	65	85	100	115	150
Wrench Size	WS	in	9/16	9/16	3/4	3/4	15/16	15/16	1-1/8	1-1/8

1) A safety factor of 1.48 was used to calculate the allowable loads. This is based on a load combination of 30% dead loads and 70% live loads.

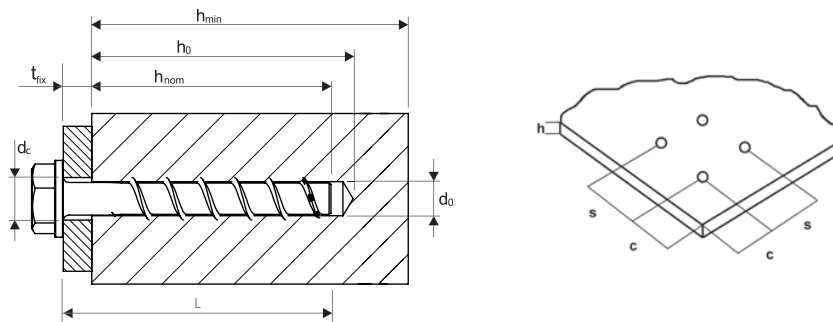

INSTALLATION

- 1 Drill hole to recommended diameter and depth.
- 2 Remove dust, rubble from the hole with compressed air.
- 3 Assemble the proper socket size onto an impact or torque wrench. Insert the anchor through the item being fastened and into the hole.
- 4 Tighten the anchor to the specified torque making sure the head is firmly against the item being fastened.

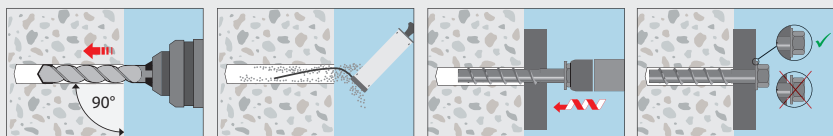

SUP-R SLEEVE

AVAILABLE MATERIALS

- Carbon steel, zinc plated
- 304 stainless steel on select sizes

FEATURES/ADVANTAGES

- Length of sleeve makes anchor more forgiving than a wedge anchor and induces less stress on the substrate
- Can be used in solid or hollow masonry
- Works in a bottomless hole
- Required hole diameter equals anchor diameter
- Supplied assembled with 4 possible head styles



APPROVALS/LISTINGS

- G.S.A. Spec A-A-1923A
- Contact customer service for approvals

CONSIDERATIONS

- Do not over-torque

AVAILABLE HEAD STYLES

ACORN NUT



HEX NUT



FLAT HEAD



ROUND HEAD



INSTALLATION

- 1 Select a carbide-tip drill bit with same nominal diameter as anchor body. Drill hole depth 1/2" to 1" deeper than anchor embedment.
- 2 Clean hole of debris.
- 3 Set nut flush with top of anchor and drive anchor through material to be anchored into the work surface until nut and washer are snug with material to be attached.
- 4 Tighten nut until finger tight, then turn 3 to 4 full turns to set the expansion sleeve.

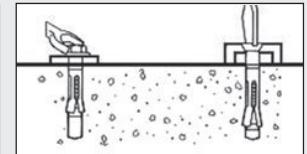
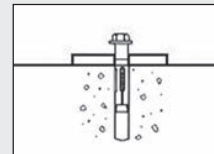
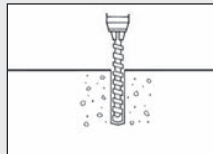

ORDER DETAIL

Carbon Steel Order Code	304 Stainless Steel Order Code	Anchor Diameter & Length	Hole Diameter	Max. Thk. Materials to be Anchored	Min. Embedment	Diameter Thread Stud	Required Torque to Set (ft. lbs.)	2000 P.S.I.		3500 P.S.I.		5000 P.S.I.		Box Qty.	Master Qty.
								Tension (lbs.)	Shear (lbs.)	Tension (lbs.)	Shear (lbs.)	Tension (lbs.)	Shear (lbs.)		
Acorn Nut															
1704000	—	1/4" x 5/8"	1/4"	1/16"	—	3/16"	5-8	—	—	—	—	—	—	100	1,200
1705000	1705SS0 ¹	1/4" x 1-3/8"	1/4"	3/8"	1"	3/16"	5-8	1,356	792	1,400	920	1,640	1,148	100	800
1706000	1706SS0 ¹	1/4" x 2-1/4"	1/4"	1-1/4"	1"	3/16"	5-8	1,356	792	1,400	920	1,640	1,148	100	800
Hex Nut															
1710000	1710SS0	5/16" x 1-1/2"	5/16"	1/8"	1-1/8"	1/4"	18-22	1,840	1,376	1,900	1,600	2,040	2,000	100	800
1711000	1711SS0	5/16" x 2-1/2"	5/16"	1-3/8"	1-1/8"	1/4"	18-22	1,840	1,376	1,900	1,600	2,040	2,000	100	500
1712000	1712SS0	3/8" x 1-7/8"	3/8"	5/8"	1-1/4"	5/16"	22-26	2,840	1,736	2,960	2,020	3,256	2,524	50	400
1713000	1713SS0	3/8" x 3"	3/8"	1-3/4"	1-1/4"	5/16"	22-26	2,840	1,736	2,960	2,020	3,256	2,524	50	250
1714000	1714SS0	1/2" x 2-1/4"	1/2"	3/4"	1-1/2"	3/8"	34-38	4,664	4,952	4,860	5,760	5,334	7,200	25	200
1715000	—	1/2" x 3"	1/2"	1-1/2"	1-1/2"	3/8"	34-38	4,664	4,952	4,860	5,760	5,334	7,200	25	200
1716000	1716SS0	1/2" x 4"	1/2"	2-1/2"	1-1/2"	3/8"	34-38	4,664	4,952	4,860	5,760	5,334	7,200	25	125
1717000	—	1/2" x 6"	1/2"	4-1/2"	1-1/2"	3/8"	34-38	4,664	4,952	4,860	5,760	5,334	7,200	15	75
1718000	—	5/8" x 2-1/4"	5/8"	1/4"	2"	1/2"	52-75	5,730	6,776	5,970	7,880	6,560	9,848	25	125
1724000	—	5/8" x 3"	5/8"	1"	2"	1/2"	52-75	5,730	6,776	5,970	7,880	6,560	9,848	15	120
1719000	1719SS0	5/8" x 4-1/4"	5/8"	2-1/4"	2"	1/2"	52-75	5,730	6,776	5,970	7,880	6,560	9,848	10	50
1720000	—	5/8" x 6"	5/8"	4"	2"	1/2"	52-75	5,730	6,776	5,970	7,880	6,560	9,848	10	50
1721000	1721SS0	3/4" x 2-1/2"	3/4"	1/2"	2"	5/8"	90-110	8,428	9,992	8,780	11,620	9,656	14,524	10	80
1722000	1722SS0	3/4" x 4-1/4"	3/4"	2-1/4"	2"	5/8"	90-110	8,428	9,992	8,780	11,620	9,656	14,524	5	40
1723000	—	3/4" x 6-1/4"	3/4"	4-1/4"	2"	5/8"	90-110	8,428	9,992	8,780	11,620	9,656	14,524	5	25
Flat Head															
1764000	—	1/4" x 1-1/2"	1/4"	1/2"	1"	3/16"	5-8	1,356	792	1,400	920	1,640	1,148	100	800
1765000	—	1/4" x 2"	1/4"	1"	1"	3/16"	5-8	1,356	792	1,400	920	1,640	1,148	100	800
1766000	—	1/4" x 3"	1/4"	2"	1"	3/16"	5-8	1,356	792	1,400	920	1,640	1,148	100	800
*1772000	—	3/8" x 2-3/4"	3/8"	1-1/2"	1-1/4"	5/16"	22-26	2,840	1,736	2,960	2,020	3,256	2,524	50	250
*1773000	1773SS0	3/8" x 4"	3/8"	2-3/4"	1-1/4"	5/16"	22-26	2,840	1,736	2,960	2,020	3,256	2,524	50	250
*1774000	—	3/8" x 5"	3/8"	3-3/4"	1-1/4"	5/16"	22-26	2,840	1,736	2,960	2,020	3,256	2,524	25	125
*1775000	—	3/8" x 6"	3/8"	4-3/4"	1-1/4"	5/16"	22-26	2,840	1,736	2,960	2,020	3,256	2,524	25	125
Round Head															
1788000	—	1/4" x 1-1/4"	1/4"	1/4"	1"	3/16"	5-8	1,356	792	1,400	920	1,640	1,148	100	800
1789000	—	1/4" x 2"	1/4"	1"	1"	3/16"	5-8	1,356	792	1,400	920	1,640	1,148	100	800
1795000	—	3/8" x 2-1/2"	3/8"	1-1/4"	1-1/4"	5/16"	22-26	2,840	1,736	2,960	2,020	3,256	2,524	50	400

* Phillips Head Only ¹Stainless Steel only available in hex nut type.

SUP-R[®] STUD[®] TZ

AVAILABLE MATERIALS

- Steel Zinc plated
- 304/316 Stainless Steel

FEATURES/ADVANTAGES

- ACI 318 category 1 anchor for cracked or uncracked concrete
- Suitable for resisting seismic design loads Category A-F
- Required hole diameter equals anchor diameter
- Can be loaded immediately
- Simple to install
- For medium to heavy loads
- Hole diameter is critical
- Concrete only

APPROVALS/LISTINGS

- ACI 318 Category 1 for cracked concrete
- ICC ESR - 2461
- Contact customer service for approvals / listings for state DOT's



ORDER DETAIL

Anchor Dimensions	Order Code	Th [in]	d _o [in]	h _o [in]	h _{nom} [in]	h _{ef} [in]	L [in]	t _{max} [in]	T _{inst} [ft-lbs]	d _c [in]	ws [in]
3/8"X3"	2138300	3/8	3/8	2-5/8	2-5/16	2	3	1	17.5	7/16	9/16
3/8"X3-3/4"	2138334	3/8	3/8	2-5/8	2-5/16	2	3-5/11	1-3/4	17.5	7/16	9/16
3/8"X5"	2138500	3/8	3/8	2-5/8	2-5/16	2	5	3	17.5	7/16	9/16
1/2" x 3-3/4"	2112334	1/2	1/2	3-1/4	2-7/8	2-1/2	3-3/4	1/4	35	9/16	3/4
1/2" x 4-1/2"	2112412	1/2	1/2	3-1/4	2-7/8	2-1/2	4-1/2	1	35	9/16	3/4
1/2" x 5-1/2"	2112512	1/2	1/2	3-1/4	2-7/8	2-1/2	5-1/2	2	35	9/16	3/4
1/2" x 7"	2112700	1/2	1/2	3-1/4	2-7/8	2-1/2	7	3-1/2	35	9/16	3/4
5/8" x 4-3/4"	2158434	5/8	5/8	4-1/8	3-3/4	3-1/4	4-3/4	1/4	65	11/16	15/16
5/8" x 6"	2158600	5/8	5/8	4-1/8	3-3/4	3-1/4	6	1-1/2	65	11/16	15/16
5/8" x 8-1/2"	2158812	5/8	5/8	4-1/8	3-3/4	3-1/4	8-1/2	4	65	11/16	15/16
5/8" x 10"	2158100	5/8	5/8	4-1/8	3-3/4	3-1/4	10	5-1/2	65	11/16	15/16
3/4 X 4-3/4"	2134434	3/4	3/4	4-1/2	4-5/16	3-3/4	4-3/4	5/8	115	13/16	1-1/8
3/4"X5-1/2"	2134512	3/4	3/4	4-1/2	4-5/16	3-3/4	5-1/2	1-3/8	115	13/16	1-1/8
3/4X6-1/4"	2134614	3/4	3/4	4-1/2	4-5/16	3-3/4	6-1/4	2-1/8	115	13/16	1-1/8

Steel zinc plated / Approved for cracked or uncracked concrete / ACI 318, Category 1

Load & Performance Data	Conc. (psi)	Symbol	Units	1/2"	5/8"
Cracked Concrete					
Avg.ultimate load,tension	4,000	N_{pn}	lbs	4,447	9,603
Avg. ultimate load, shear	4,000	V_n	lbs	9,621	14,859
Allowable loads, tension ¹	2,500	N_{allow}	lbs	1,234	2,187
	4,000	N_{allow}	lbs	1,561	2,767
	6,000	N_{allow}	lbs	1,912	3,388
	8,500	N_{allow}	lbs	2,276	4,034
Uncracked Concrete					
Allowable loads, tension ¹	2,500	N_{allow}	lbs	1,974	3,088
	4,000	N_{allow}	lbs	2,497	3,906
	6,000	N_{allow}	lbs	3,059	4,784
	8,500	N_{allow}	lbs	3,641	5,694
Cracked and Uncracked Concrete					
Allowable loads, shear ¹	2,500	V_{allow}	lbs	3,178	4,711
	>4,000	V_{allow}	lbs	3,259	4,839

Spacing & Edge Distance

Effective anchorage depth	h_{ef}	in	2 1/2	3 1/4
Critical Spacing	S_{ac}	in	16	19 1/2
Critical Edge Distance	C_{ac}	in	8	9 3/4
Minimum Spacing for Edge Distance C	$S_{a,min}/C$	in	2 1/2 / 5	3 / 6
Minimum Edge Distance for Spacing S	$C_{a,min}/S$	in	3 / 6	3 1/2 / 9 1/2
Minimum thickness of concrete slab	h_{min}	in	5	6 1/2

Installation Parameters

Drilled hole diameter	d_o	in	1/2	5/8
Diameter of clearance hole	d_c	in	9/16	11/16
Depth of drilled hole	h_o	in	3 1/4	4 1/8
Installation torque	T_{inst}	ft-lbs	35	65
Wrench size	WS	in	3/4	15/16

1) A safety factor of 1.48 was used to calculate the allowable loads. This is based on a load combination of 30% dead loads and 70% live loads.

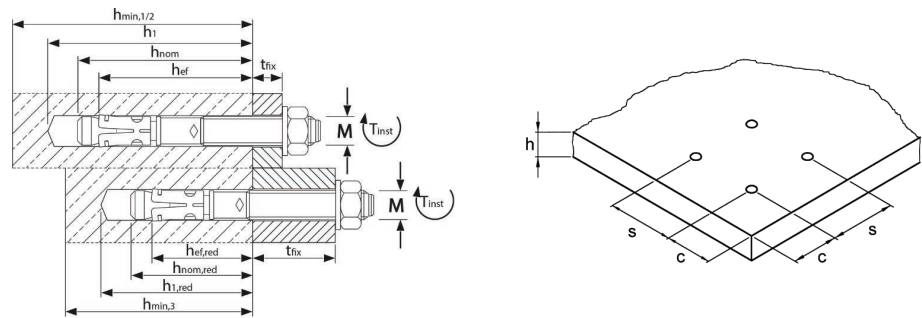

INSTALLATION

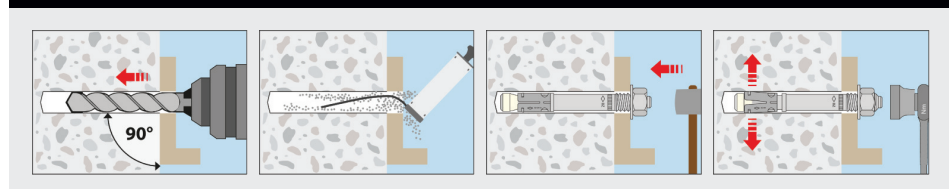

SUP-R[®] STUD[®] TZ SS

AVAILABLE MATERIALS

- 304/316 Stainless Steel

FEATURES/ADVANTAGES

- ACI 318 category 1 anchor for cracked or uncracked concrete
- Suitable for resisting seismic design loads
- Required hole diameter equals anchor diameter
- Can be loaded immediately
- Nut and washer assembled to anchor
- Simple to install
- For medium to heavy loads

CONSIDERATIONS

- Hole diameter is critical
- Concrete only

APPROVALS/LISTINGS

- ACI 318 Category 1 for cracked concrete
- ICC ESR - 2461
- Contact customer service for approvals / listings for state DOT's



ORDER DETAIL

Anchor Dimensions	Order Code 304	Order Code 316SS	Th [in]	d _a [in]	h _c [in]	h _{nom} [in]	h _{st} [in]	L [in]	t _{max} [in]	T _{inst} [ft-lbs]	d _c [in]	w _c [in]
1/2" x 3-3/4"	2312334	231233S	1/2	1/2	3-1/4	2-7/8	2-1/2	3-3/4	1/4	60	9/16	3/4
1/2" x 4-1/2"	2312412	231241S	1/2	1/2	3-1/4	2-7/8	2-1/2	4-1/2	1	60	9/16	3/4
1/2" x 5-1/2"	2312512	231251S	1/2	1/2	3-1/4	2-7/8	2-1/2	5-1/2	2	60	9/16	3/4
1/2" x 7"	2312700	231270S	1/2	1/2	3-1/4	2-7/8	2-1/2	7	3-1/2	60	9/16	3/4
304/316SS												
5/8" x 4-3/4"	2358434	235843S	5/8	5/8	4-1/8	3-3/4	3-1/4	4-3/4	1/4	110 / 96	11/16	15/16
5/8" x 6"	2358600	235860S	5/8	5/8	4-1/8	3-3/4	3-1/4	6	1-1/2	110 / 96	11/16	15/16
5/8" x 8-1/2"	2358812	235881S	5/8	5/8	4-1/8	3-3/4	3-1/4	8-1/2	4	110 / 96	11/16	15/16
5/8" x 10"	2358100	235810S	5/8	5/8	4-1/8	3-3/4	3-1/4	10	5-1/2	110 / 96	11/16	15/16

304 Stainless Steel / 316 Stainless steel / Approved for cracked or uncracked concrete / ACI 318, Category 1

Load & Performance Data	Conc. (psi)	Symbol	Units	1/2"	5/8"
Cracked Concrete					
Avg.ultimate load,tension	4,000	N_{pn}	lbs	4,447	9,603
Avg. ultimate load, shear	4,000	V_n	lbs	9,615	15,345
Allowable loads, tension ¹	2,500	N_{allow}	lbs	1,234	2,187
	4,000	N_{allow}	lbs	1,561	2,767
	6,000	N_{allow}	lbs	1,912	3,388
	8,500	N_{allow}	lbs	2,276	4,033
Uncracked Concrete					
Allowable loads, tension ¹	2,500	N_{allow}	lbs	1,974	3,088
	4,000	N_{allow}	lbs	2,497	3,906
	6,000	N_{allow}	lbs	3,058	4,784
	8,500	N_{allow}	lbs	3,640	5,694
Cracked and Uncracked Concrete					
Allowable loads, shear ¹	2,500	N_{allow}	lbs	2,824	4,711
	>4,000	N_{allow}	lbs	2,824	5,617

Spacing & Edge Distance

Effective anchorage depth	h_{ef}	in	2 1/2	3 3/4	
Critical spacing	S_{ac}	in	16	19 1/2	
Critical Edge Distance	C_{ac}	in	8	9 3/4	
Cracked and Uncracked Concrete					
Minimum Spacing for Edge Distance C	$S_{a,min}/C$	in	2 1/2 / 5	3 / 6	
Minimum Edge Distance for Spacing S	$C_{a,min}/S$	in	3 / 6	3 1/2 / 9 1/2	
Minimum thickness of concrete slab	h_{min}	in	5	6 1/2	

Installation Parameters

Drilled hole diameter	d_o	in	1/2	5/8
Diameter of clearance hole	d_c	in	9/16	11/16
Depth of drilled hole	h_o	in	3 1/4	4 1/8
Installation torque	T_{inst}	ft-lbs	60	110 / 96
Wrench size	WS	in	3/4	15/16

1) A safety factor of 1.48 was used to calculate the allowable loads. This is based on a load combination of 30% dead loads and 70% live loads.

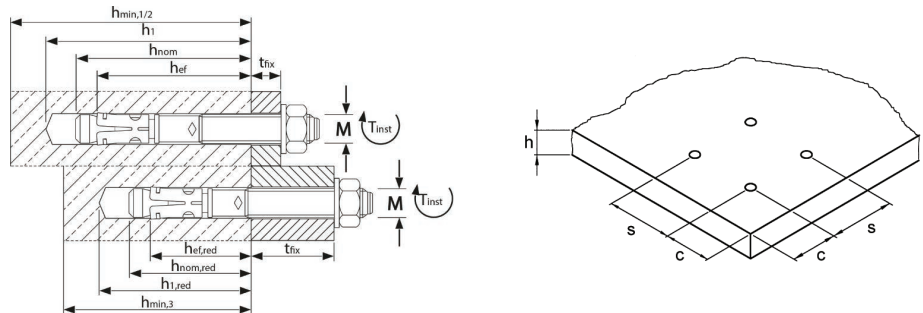

INSTALLATION

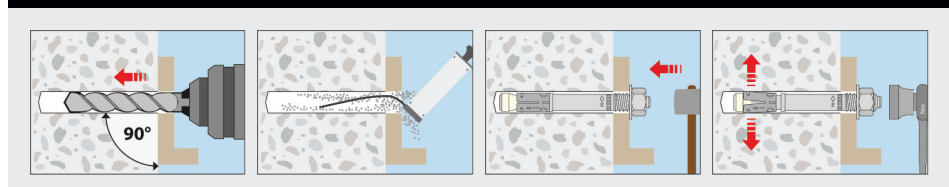

SUP-R[®] STUD[®] V-TZ

AVAILABLE MATERIALS

- Carbon steel, zinc plated
- Carbon steel clip, sheradized

FEATURES/ADVANTAGES

- ACI 318 category 1 anchor for cracked or uncracked concrete
- Suitable for resisting seismic design loads
- Required hole diameter equals anchor diameter
- Category A-F
- Can be loaded immediately
- Simple to install
- For medium to heavy loads

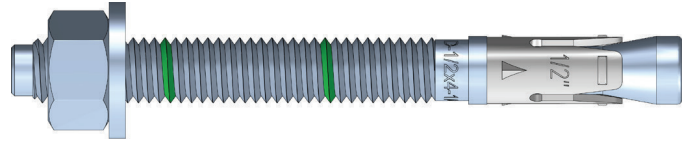

APPROVALS/LISTINGS

- ACI 318 Category 1 for cracked concrete
- ICC-ES ESR 4278
- Contact customer service for approvals / listings for state DOT's



CONSIDERATIONS

- Hole diameter is critical
- Concrete only

ORDER DETAIL

Anchor Dimensions	Order Code	Th [in]	d _c [in]	h _c [in]	h _{min} [in]	h _{max} [in]	L [in]	t _{min} [in]	T _{min} [ft-lbs]	d _h [in]	w _c [in]
3/8" x 3"	2038300	3/8	3/8	2-5/8	2-3/8	2	3	1/4	30	7/16	9/16
3/8" x 3-3/4"	2038334	3/8	3/8	2-5/8	2-3/8	2	3-3/4	1	30	7/16	9/16
3/8" x 5"	2038500	3/8	3/8	2-5/8	2-3/8	2	5	2-1/4	30	7/16	9/16
1/2" x 3-3/4"	2012334	1/2	1/2	2-5/8	2-3/8	2	3-3/4	7/8	45	9/16	3/4
1/2" x 4-1/4"	2012414	1/2	1/2	2-5/8	2-3/8	2	4-1/4	1-3/8	45	9/16	3/4
1/2" x 5-1/2"	2012512	1/2	1/2	2-5/8	2-3/8	2	5-1/2	2-5/8	45	9/16	3/4
1/2" x 7"	2012700	1/2	1/2	2-5/8	2-3/8	2	7	4-1/8	45	9/16	3/4
1/2" x 8-1/2"	2012812	1/2	1/2	2-5/8	2-3/8	2	8-1/2	5-5/8	45	9/16	3/4
5/8" x 4-1/2"	2058412	5/8	5/8	3-1/2	3-1/4	2-3/4	4-1/2	5/8	75	11/16	15/16
5/8" x 5"	2058500	5/8	5/8	3-1/2	3-1/4	2-3/4	5	1-1/8	75	11/16	15/16
5/8" x 6"	2058600	5/8	5/8	3-1/2	3-1/4	2-3/4	6	2-1/8	75	11/16	15/16
5/8" x 7"	2058700	5/8	5/8	3-1/2	3-1/4	2-3/4	7	3-1/8	75	11/16	15/16
5/8" x 8-1/2"	2058812	5/8	5/8	3-1/2	3-1/4	2-3/4	8-1/2	4-5/8	75	11/16	15/16
5/8" x 10"	2058100	5/8	5/8	3-1/2	3-1/4	2-3/4	10	6-1/8	75	11/16	15/16
3/4" x 5-1/2"	2034512	3/4	3/4	4	3-3/4	3-1/4	5-1/2	1	150	7/8	1-1/8
3/4" x 6-1/4"	2034614	3/4	3/4	4	3-3/4	3-1/4	6-1/4	1-3/4	150	7/8	1-1/8
3/4" x 7"	2034700	3/4	3/4	4	3-3/4	3-1/4	7	2-1/2	150	7/8	1-1/8
3/4" x 8-1/2"	2034812	3/4	3/4	4	3-3/4	3-1/4	8-1/2	4	150	7/8	1-1/8
3/4" x 10"	2034100	3/4	3/4	4	3-3/4	3-1/4	10	5-1/2	150	7/8	1-1/8

Steel zinc plated / Approved for cracked or uncracked concrete / ACI 318, Category 1

Load & Performance Data	Conc. (psi)	Symbol	Units	3/8"	1/2"	5/8"	3/4"
Cracked Concrete							
Avg. ultimate load, tension	4,000	N_{dn}	lbs	2,736	4,293	3,937	5,058
Avg. ultimate load, shear	4,000	V_n	lbs	1,859	2,129	5,876	7,995
Allowable loads, tension ¹	2,500	N_{allow}	lbs	950	1,056	2,103	2,702
	4,000	N_{allow}	lbs	1,202	1,336	2,660	3,418
	6,000	N_{allow}	lbs	1,472	1,636	3,258	4,186
	8,500	N_{allow}	lbs	1,752	1,947	3,878	4,982
Uncracked Concrete							
Allowable loads, tension ¹	2,500	N_{allow}	lbs	1,460	1,491	2,403	3,474
	4,000	N_{allow}	lbs	1,746	1,886	3,040	3,906
	6,000	N_{allow}	lbs	2,037	2,309	3,723	4,784
	8,500	N_{allow}	lbs	2,325	2,749	4,432	5,694
Allowable loads, tension - light weight	3,000	N_{allow}	lbs	611	980	1,580	2,283
Cracked and Uncracked Concrete							
Allowable loads, shear ¹	2,500	V_{allow}	lbs	1,137	1,137	3,970	5,402
	>4,000	V_{allow}	lbs	1,256	1,438	3,970	5,402
Allowable loads, shear - light weight	3,000	V_{allow}	lbs	633	633	2,041	2,951

Spacing & Edge Distance

Effective anchorage depth	h_{ef}	in	2	2	2-3/4	3-1/4
Critical Edge Distance	C_{ac}	in	6	6	7	9
Minimum Spacing for Edge Distance C	$S_{a,min}/C$	in	2-1/2 / 4	2-3/4 / 6	4-1/2 / 6	5 / 10-1/2
Minimum Edge Distance for Spacing S	$C_{a,min}/S$	in	2-1/2 / 6-1/2	3 / 6	3-1/2 / 8	5 / 10-1/2
Minimum thickness of concrete slab	h_{min}	in	4	4	5-1/2	6

Installation Parameters

Drilled hole diameter	d_o	in	3/8	1/2	5/8	3/4
Diameter of clearance hole	d_c	in	7/16	9/16	11/16	7/8
Depth of drilled hole	h_o	in	2-5/8	2-5/8	3-1/2	4
Installation torque	T_{inst}	ft-lbs	30	45	75	150
Wrench size	WS	in	9/16	3/4	15/16	1-1/8

1) A safety factor of 1.48 was used to calculate the allowable loads. This is based on a load combination of 30% dead loads and 70% live loads.

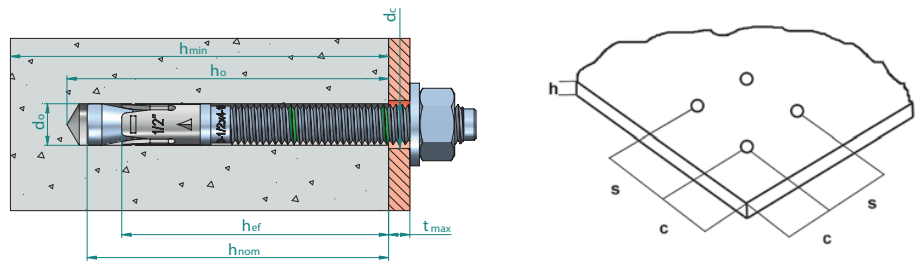

INSTALLATION

- 1 Select the correct diameter drill bit, drill a hole to minimum required hole depth or deeper.
- 2 Remove drilling debris from the bottom of the drill hole using a brush and a blowout bulb, compressed air or vacuum.
- 3 Assemble the nut & washer past the impact end of the SRS V-TZ. Use a hammer to tap the anchor through the part being fastened into the drilled hole until the washer is in contact with the part.
- 4 Using a torque wrench, apply the specified installation torque.

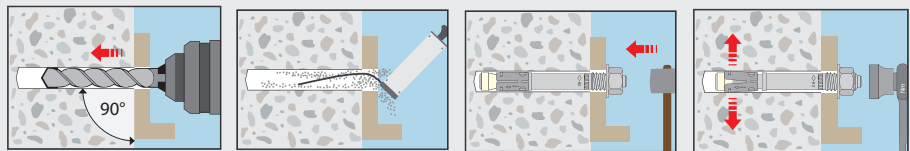

SUP-R[®] STUD + INTERNAL THREAD

AVAILABLE MATERIALS

- Carbon steel, zinc plated
- 304 / 316 Stainless Steel

FEATURES/ADVANTAGES

- Can be installed in an ANSI standard hole
- The fixture is easily removed
- Closer anchor spacing and edge distance than with drop-in
- Can be set in a bottomless hole
- No unsightly stud protruding from hole



APPLICATIONS:

- Medium duty anchoring where the use of internal thread is required and/or anchor spacing and edge distance are closer than those needed for drop-in anchor: Suspended ceilings, fastening of flat steel structures, ducts, vent systems, railings, etc.

APPROVALS/LISTINGS

- Jobsite approvals for North Dakota, South Carolina, Vermont

CONSIDERATIONS

- Use in solid concrete only

ORDER DETAIL

Order Code	Bolt Size	Min Hole	Embed	Set	Install	Install	Drill Bit	4000 psi Concrete	
		Depth (Inch)	Depth (Inch)	Depth (Inch)	Torque (ft-lbs)	Turns (-)	Diameter (inches)	Tension* (lbf)	Shear* (lbf)
263823I	3/8"	3-1/4	3	5/16	15	2.5	1/2	7,559	4,414
261231I	1/2"	4-1/4	3-5/8	3/8	35	3.5	5/8	9,719	6,105
265840I	5/8"	5	4-3/8	1/2	80	4.5	7/8	16,804	13,439
263445I	3/4"	5-3/4	5-1/4	9/16	120	4	1	21,607	18,814
261514I	1"	6-1/2	6	5/8	200	4	1-1/4	23,921	19,137

*Load values are based on using A307 bolts to complete the fastening. When installing the SRS+ IT through the item fastened, add the fixture thickness to the setting depth in the table

INSTALLATION

- 1 Select the correct diameter drill bit and drill the hole to the required hole depth.
- 2 Remove the debris from the hole using a blowout bulb, compressed air, or a vacuum.
- 3 Thread the setting bolt into the anchor adjusting for setting depth as per the chart.
- 4 Place the anchor in the hole(1) and hammer the setting bolt until the washer makes contact with the surface of the concrete(2).
- 5 Remove the bolt (1) and place the fixture over the hole (2), Start the bolt through the fixture into the anchor.
- 6 Tighten the bolt to required torque as per table, Once the appropriate torque is achieved, the anchor is set.

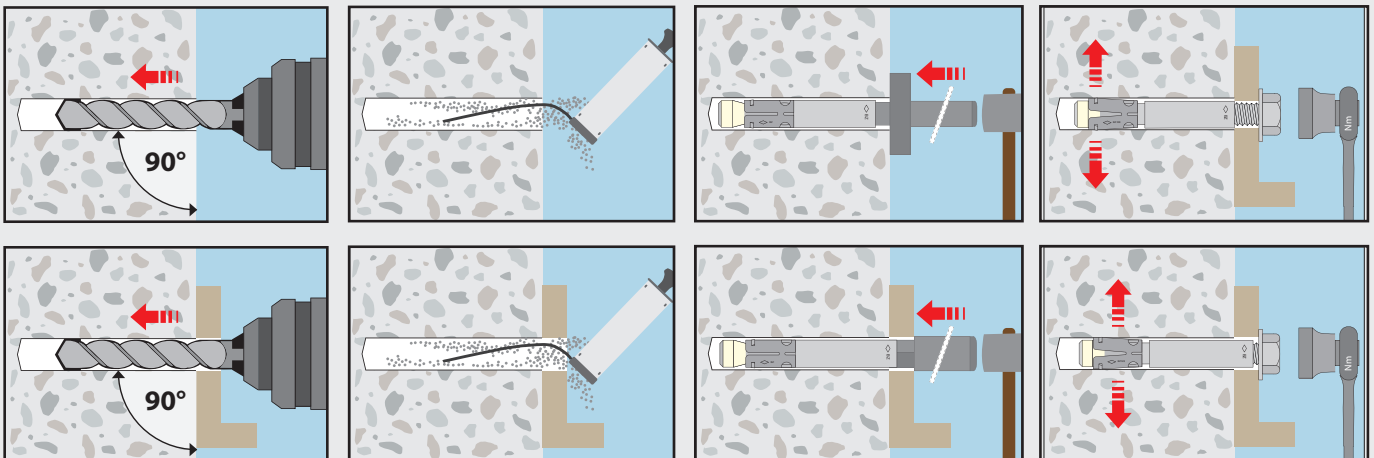

The background features a series of thin, parallel, light-colored diagonal lines that create a sense of depth and movement. A solid red vertical bar is positioned on the right side of the image. The text is centered in the lower half of the frame.

LIGHT DUTY

ANCHORING SYSTEMS



AVAILABLE MATERIALS

- Extruded lead shield with a diecast zinc expander nut

FEATURES/ADVANTAGES

- Light to medium loads under dead or variable conditions in a variety of solid masonry
- Lead flows into hole irregularities, making base material firmer than before anchoring
- Highly corrosion resistant
- Can remove or replace fixture and refasten without loss of holding power
- Setting tool included in each box

APPROVALS/LISTINGS

- G.S.A. Spec A-A-1922A, CID TYPE 1
- Contact customer service for approvals

ORDER DETAIL

Ultimate Loads in Lbs.*
*Tested in 3000 P.S.I. Concrete
1 tool included with each box of anchors

Order Code	Bolt Diameter	Hole Diameter	Shield Length	Tension	Shear	Box Qty.	Master Qty.
1405000	10-24	3/8"	5/8"	950	1,200	100	800
1407000	1/4"-20	1/2"	7/8"	2,120	2,070	100	800
1408000	5/16"-18	5/8"	1"	2,900	2,400	100	500
1409000	3/8"-16	3/4"	1-1/4"	5,250	4,180	50	250
1411000	1/2"-13	7/8"	1-1/2"	6,080	5,000	25	125

INSTALLATION

- 1 Drill recommended diameter hole to depth of shield.
- 2 Clean hole of debris.
- 3 Insert anchor in hole threaded end first.
- 4 Caulk with caulking tool supplied with anchors. Deliver blows with hammer until anchor is tight.
- 5 Place fixture over anchor. Insert machine bolt.
- 6 Tighten bolt.

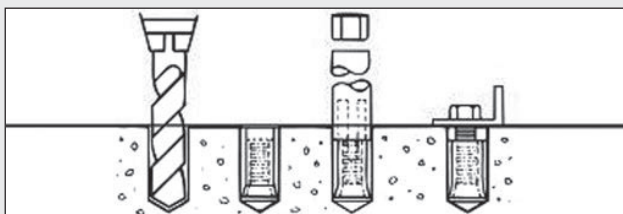

AVAILABLE MATERIALS

- Lead alloy, die cast

FEATURES/ADVANTAGES

- Light to medium loads in a variety of solid masonry
- Highly corrosion resistant

APPROVALS/LISTINGS

- G.S.A. Spec A-A-55615
- Contact customer service for approvals

CONSIDERATIONS

- Dead loads only

ORDER DETAIL

Ultimate Loads in Lbs.*
*Tested in 3000 P.S.I. Concrete

Order Code	Size	Hole Diameter	Tension	Box Qty.	Master Qty.
3531000	6-8 x 3/4"	1/4"	183	100	3,000
3532000	6-8 x 1"	1/4"	183	100	3,000
3533000	6-8 x 1-1/2"	1/4"	183	50	1,500
3535000	10-14 x 3/4"	5/16"	310	100	3,000
3536000	10-14 x 1"	5/16"	310	100	1,200
3537000	10-14 x 1-1/2"	5/16"	310	100	1,200
3541000	16-18 x 1"	3/8"	415	100	1,200
3542000	16-18 x 1-1/2"	3/8"	415	100	800

INSTALLATION

- 1 Drill recommended diameter hole to depth of shield.
- 2 Clean hole of debris.
- 3 Insert lead anchor into hole.
- 4 Place fixture over anchor, insert screw and tighten. Screw length must be length of anchor plus thickness of material to be fastened.

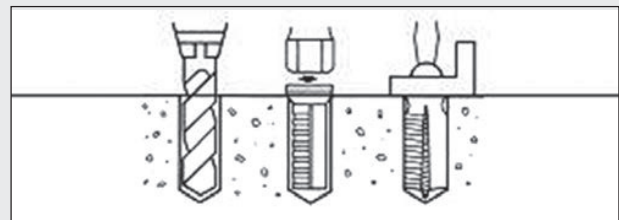



AVAILABLE MATERIALS

- The head is a formed, steel stamping with or without machine screws or hanger bolt, zinc plated
- Combo heads available on most sizes

FEATURES/ADVANTAGES

- Light to medium loads under dead or variable conditions in a variety of hollow base materials
- Wings lock quickly and positively after insertion through the wall

CONSIDERATIONS

- Hollow construction only

ORDER DETAIL

Hanger Type					Heads Only			
Order Code	Screw Size	Hole Dia.	Box Qty.	Master Qty.	Order Code	Size	Box Qty.	Master Qty.
8320500	3/16" x 4"	1/2"	50	150	8307000	1/8"	100	1,200
8325500	3/16" x 5"	1/2"	50	150	8317000	3/16"	100	800
8340500	1/4" x 4"	1/4"	50	150	8337000	1/4"	100	500
8345500	1/4" x 5"	1/4"	50	100	8357000	5/16"	100	300
					8377000	3/8"	100	200
					8387000	1/2"	25	75

ORDER DETAIL

Order Code	Screw Size	Available Screw Type	Hole Diameter	Tension 1/2" Dry Wall	Box Qty.	Master Qty.
8303000 (#6)	1/8" x 2"	RM	3/8"	120	50	1500
8305000	1/8" x 3"	RM	3/8"	120	50	1500
8310000	1/8" x 4"	RM	3/8"	120	50	600
8313000 (#10)	3/16" x 2"	R	1/2"	135	50	600
8315000	3/16" x 3"	RM	1/2"	135	50	400
8320000	3/16" x 4"	RM	1/2"	135	50	400
8325000	3/16" x 5"	R	1/2"	135	50	250
8330000	3/16" x 6"	R	1/2"	135	50	250
8335000	1/4" x 3"	RM	11/16"	145	50	400
8340000	1/4" x 4"	RM	11/16"	145	50	250
8345000	1/4" x 5"	R	11/16"	145	50	250
8350000	1/4" x 6"	R	7/8"	145	50	250
8355000	5/16" x 3"	R	7/8"	160	50	250
8360000	5/16" x 4"	R	7/8"	160	50	150
8362000	5/16" x 5"	R	7/8"	160	50	150
8365000	5/16" x 6"	R	7/8"	160	50	150
8370000	3/8" x 3"	R	7/8"	160	50	150
8375000	3/8" x 4"	R	7/8"	160	50	150
8378000	3/8" x 5"	R	7/8"	160	50	100
8380000	3/8" x 6"	R	7/8"	160	50	100
8385000	1/2" x 4"	R	1-1/4"	185	25	50
8390000	1/2" x 6"	R	1-1/4"	185	25	50

R = Round Head, ex. 8315000
M = Mushroom Head - 2 on order code, ex. 8315200

INSTALLATION

- 1 Drill recommended diameter hole through base material.
- 2 Clean hole of debris.
- 3 Insert bolt through fixture to be fastened, screw wing nut onto bolt.
- 4 Push wing through drilled hole.
- 5 Tighten screw.

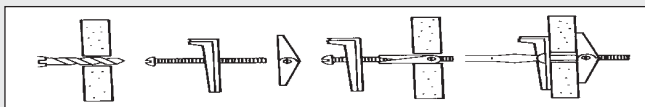

AVAILABLE MATERIALS

- Polypropylene

FEATURES/ADVANTAGES

- Light loads only under dead or slightly variable conditions in all atmospheric conditions
- Accepts both wood and sheet metal screws
- Fast, easy installation

ORDER DETAIL

Order Code	Diameter & Length	Hole Dia.	Screw Size	Ultimate Tension in Lbs.* Screw Size Tested				Box Qty.	Master Qty.
				8 x 1-1/4"	10 x 1-1/4"	10 x 1-1/2"	12 x 1-1/2"		
8450000	3/16" x 7/8"	3/16"	8-10	115	385	—	—	100	3,000
8451000	3/16" x 7/8"	3/16"	8-10	115	385	—	—	1,000	5,000
8460000	1/4" x 1"	1/4"	10-12	—	—	195	543	100	3,000
8461000	1/4" x 1"	1/4"	10-12	—	—	195	543	1,000	3,000
8430000	5/16" x 1-3/8"	5/16"	14-16	n/a	n/a	n/a	n/a	100	1,200

Kits With Drill And Screws

**8450100	3/16" x 7/8"	3/16"	8	115	385	—	—	1	12
**8460100	1/4" x 1"	1/4"	10	—	—	195	543	1	12

*Tested in concrete block.

**Includes Carbide Drill Bit and 100 Anchors and Screws

INSTALLATION

- 1 Drill recommended diameter hole slightly deeper than length of anchor.
- 2 Clean hole of debris.
- 3 Insert plastic anchor into hole.
- 4 Place fixture over anchor and insert screw through fixture and into anchor.
- 5 Tighten screw.

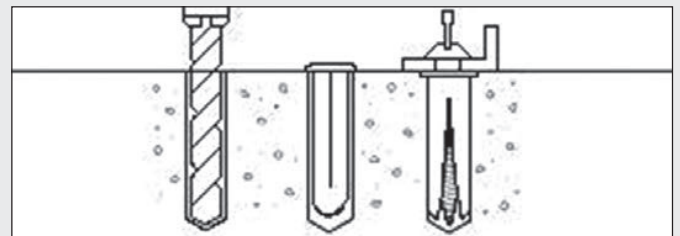

CONSET

AVAILABLE MATERIALS

- High strength steel
- Flat head and hex head

FEATURES/ADVANTAGES

- For use in all types of solid & hollow masonry, wood and stone
- Fluorocarbon coating offers high resistance to corrosion
- Cuts its own threads
- Hex head version offers 2 drive methods
- Fast, easy installation
- Drill bit included in each box
- Coating withstands 1000 hours of salt spray test

APPROVALS/LISTINGS

- Miami Dade approved
- Tested in accordance with AC193, AC106, AC233, AC257

CONSIDERATIONS

- Softer base materials require undersized bits for best results

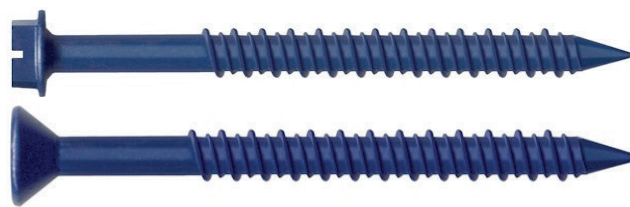

HHWF = Hex Head Washer Faced
PF = Phillips Flat
1 drill bit included in each box

ORDER DETAIL

Ultimate Tensile & Shear Loads in lbs.

Order Code	Head Style	Anchor Size	Bit. Dia. & Length	Maximum Thickness of Fixture	Embedment	Tension (lbs.)	Shear (lbs.)	Embed.	Tension (lbs.)	Box Qty.	Master Qty.
H3125	HHWF	3/16" x 1-1/4"	5/32" x 3-1/2"	0" - 1/4"	1"	875	1,170	1-1/4"	430	100	3,000
H3175	HHWF	3/16" x 1-3/4"	5/32" x 3-1/2"	1/4" - 3/4"	1"	875	1,170	1-1/4"	430	100	1,200
H3225	HHWF	3/16" x 2-1/4"	5/32" x 4-1/2"	3/4" - 1-1/4"	1"	875	1,170	1-1/4"	430	100	1,200
H3275	HHWF	3/16" x 2-3/4"	5/32" x 4-1/2"	1-1/4" - 1-3/4"	1"	875	1,170	1-1/4"	430	100	1,200
H3325	HHWF	3/16" x 3-1/4"	5/32" x 5-1/2"	1-3/4" - 2-1/4"	1"	875	1,170	1-1/4"	430	100	800
H3375	HHWF	3/16" x 3-3/4"	5/32" x 5-1/2"	2-1/4" - 2-3/4"	1"	875	1,170	1-1/4"	430	100	800
H3400	HHWF	3/16" x 4"	5/32" x 5-1/2"	2-1/2" - 3"	1"	875	1,170	1-1/4"	430	100	800
P3125	PF	3/16" x 1-1/4"	5/32" x 3-1/2"	0" - 1/4"	1"	875	1,170	1-1/4"	430	100	3,000
P3175	PF	3/16" x 1-3/4"	5/32" x 3-1/2"	1/4" - 3/4"	1"	875	1,170	1-1/4"	430	100	1,200
P3225	PF	3/16" x 2-1/4"	5/32" x 4-1/2"	3/4" - 1-1/4"	1"	875	1,170	1-1/4"	430	100	1,200
P3275	PF	3/16" x 2-3/4"	5/32" x 4-1/2"	1-1/4" - 1-3/4"	1"	875	1,170	1-1/4"	430	100	1,200
P3325	PF	3/16" x 3-1/4"	5/32" x 5-1/2"	1-3/4" - 2-1/4"	1"	875	1,170	1-1/4"	430	100	800
P3375	PF	3/16" x 3-3/4"	5/32" x 5-1/2"	2-1/4" - 2-3/4"	1"	875	1,170	1-1/4"	430	100	800
P3400	PF	3/16" x 4"	5/32" x 5-1/2"	2-1/2" - 3"	1"	875	1,170	1-1/4"	430	100	800
H4125	HHWF	1/4" x 1-1/4"	3/16" x 3-1/2"	0" - 1/4"	1"	1,480	1,568	1-1/4"	550	100	3,000
H4175	HHWF	1/4" x 1-3/4"	3/16" x 3-1/2"	1/4" - 3/4"	1"	1,480	1,568	1-1/4"	550	100	1,200
H4225	HHWF	1/4" x 2-1/4"	3/16" x 4-1/2"	3/4" - 1-1/4"	1"	1,480	1,568	1-1/4"	550	100	1,200
H4275	HHWF	1/4" x 2-3/4"	3/16" x 4-1/2"	1-1/4" - 1-3/4"	1"	1,480	1,568	1-1/4"	550	100	800
H4325	HHWF	1/4" x 3-1/4"	3/16" x 5-1/2"	1-3/4" - 2-1/4"	1"	1,480	1,568	1-1/4"	550	100	800
H4375	HHWF	1/4" x 3-3/4"	3/16" x 5-1/2"	2-1/4" - 2-3/4"	1"	1,480	1,568	1-1/4"	550	100	800
H4400	HHWF	1/4" x 4"	3/16" x 5-1/2"	2-1/2" - 3"	1"	1,480	1,568	1-1/4"	550	100	800
P4125	PF	1/4" x 1-1/4"	3/16" x 3-1/2"	0" - 1/4"	1"	1,480	1,568	1-1/4"	550	100	3,000
P4175	PF	1/4" x 1-3/4"	3/16" x 3-1/2"	1/4" - 3/4"	1"	1,480	1,568	1-1/4"	550	100	1,200
P4225	PF	1/4" x 2-1/4"	3/16" x 4-1/2"	3/4" - 1-1/4"	1"	1,480	1,568	1-1/4"	550	100	1,200
P4275	PF	1/4" x 2-3/4"	3/16" x 4-1/2"	1-1/4" - 1-3/4"	1"	1,480	1,568	1-1/4"	550	100	800
P4325	PF	1/4" x 3-1/4"	3/16" x 5-1/2"	1-3/4" - 2-1/4"	1"	1,480	1,568	1-1/4"	550	100	800
P4375	PF	1/4" x 3-3/4"	3/16" x 5-1/2"	2-1/4" - 2-3/4"	1"	1,480	1,568	1-1/4"	550	100	800
P4400	PF	1/4" x 4"	3/16" x 5-1/2"	2-1/2" - 3"	1"	1,480	1,568	1-1/4"	550	100	800

INSTALLATION

- 1 Insert the masonry drill bit in the bit holder and drill the pilot hole 1/2" deeper than fastener penetration. The driving sleeve or main body of the Conset tool is snapped into position over the drill bit.
- 2 Clean hole of debris.
- 3 Position the material being fastened, and drive the Conset anchor into the masonry, under rotation only.



SUP-R SPLIT

AVAILABLE MATERIALS

- High strength, heat treated alloy steel, zinc plated
- Flat head
- Nickel rich electroplate for corrosive environments (167412OCR + 167414OCR)

FEATURES/ADVANTAGES

- Required hole diameter equals anchor diameter
- Friction set in solid masonry or stone
- High strength, heat treated alloy steel
- Corrosion resistant (CR) for use in harsh climates or with ACQ lumber



APPROVALS/LISTINGS

- G.S.A. Spec A-A-1925A, CID TYPE 2
- Contact customer service for approvals

CONSIDERATIONS

- Dead loads only

ORDER DETAIL

Ultimate Loads in lbs.

Order Code	Size	Hole Dia	Tension (lbs.)	Shear (lbs.)	Minimum Embedment	Box Qty.	Master Qty.
1674060	1/4" x 1-1/2"	1/4"	2,010	2,230	1-1/8"	100	800
1674080	1/4" x 2"	1/4"	2,010	2,230	1-1/8"	100	800
1674100	1/4" x 2-1/2"	1/4"	2,010	2,230	1-1/8"	100	800
1674120	1/4" x 3"	1/4"	2,010	2,230	1-1/8"	100	800
167412OCR	1/4" x 3"	1/4"	2,010	2,230	1-1/8"	100	800
1674140	1/4" x 3-1/2"	1/4"	2,010	2,230	1-1/8"	100	800
167414OCR	1/4" x 3-1/2"	1/4"	2,010	2,230	1-1/8"	100	800
1674160	1/4" x 4"	1/4"	2,010	2,230	1-1/8"	100	800

* Tested in 3000 P.S.I. Concrete

INSTALLATION

- 1 Using a carbide bit, drill hole at least a 1/4" deeper than the anchor embedment.
- 2 Clean hole of debris.
- 3 To set, drive anchor into hole through item to be fastened.

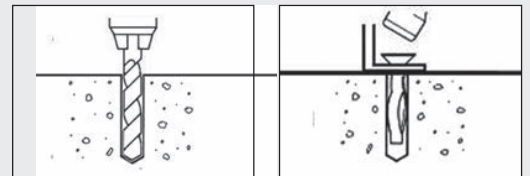

IMPORT SINGLE

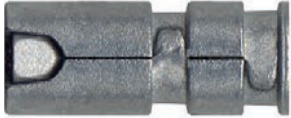

AVAILABLE MATERIALS

- Diecast zinc alloy

FEATURES/ADVANTAGES

- Medium loads under dead, variable or vibratory conditions in all types of solid masonry
- Available in single version (1 expander nut) or double version (2 expander nuts)
- Female threads accept standard UNC bolts or threaded rods

APPROVALS/LISTINGS

- G.S.A. Spec A-A-1923A, CID TYPE 2
- Contact customer service for approvals

ORDER DETAIL

Order Code	Bolt Dia.	Hole Dia.	Shield Length	Ultimate Loads in Lbs. 3000 P.S.I.			
				Tension	Shear	Box Qty.	Master Qty.
6104000	1/4"	1/2"	1-5/16"	2,410	1,750	100	800
6105000	5/16"	5/8"	1-1/2"	2,620	2,400	50	400
6106000	3/8"	5/8"	1-1/2"	4,950	3,180	50	400
6108000	1/2"	7/8"	2-3/16"	7,550	6,500	50	150

IMPORT DOUBLE

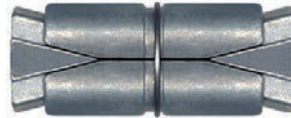

FEATURES/ADVANTAGES

- Medium loads under dead, variable or vibratory conditions in all types of solid masonry
- 2 expander nuts; also available in single version with 1 expander nut
- Female threads accept standard UNC bolts or threaded rods

APPROVALS/LISTINGS

- G.S.A. Spec A-A-1923A, CID TYPE 3
- Contact customer service for approvals

ORDER DETAIL

Order Code	Bolt Dia.	Hole Dia.	Shield Length	Ultimate Loads in Lbs. 3000 P.S.I.			
				Tension	Shear	Box Qty.	Master Qty.
6204000	1/4"	1/2"	1-3/8"	2,820	2,250	100	800
6205000	5/16"	5/8"	1-3/16"	2,990	2,740	100	500
6206000	3/8"	3/4"	2-1/16"	5,995	3,610	50	250
6208000	1/2"	7/8"	2-1/2"	9,140	7,345	25	125
6210000	5/8"	1"	3"	12,050	10,700	50	100

INSTALLATION

- 1 Drill recommended diameter hole to depth of shield.
- 2 Clean hole of debris.
- 3 Insert shield in hole threaded end first and tap with hammer for proper positioning.
- 4 Place equipment over shield. Insert machine bolt through equipment into shield and tighten.

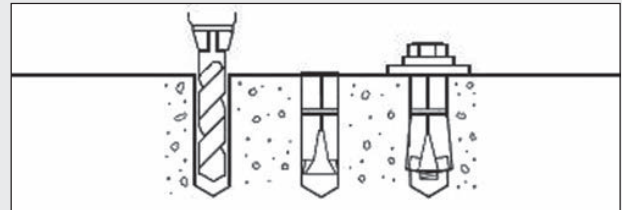

SELF-DRILLING WALLBOARD

AVAILABLE MATERIALS

- Zinc diecast alloy
- High strength nylon

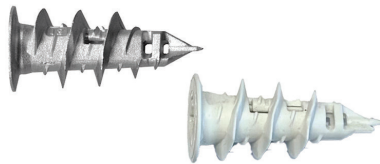

CONSIDERATIONS

- Hollow wall anchoring only

FEATURES/ADVANTAGES

- Works in any wallboard thickness
- Can be easily backed out
- Low profile head
- Fast, easy installation
- Zinc Anchor can be set with a 1/4" hex bit tip

ORDER DETAIL

Order Code	Description	Maximum Fixture Thickness	1/2" Drywall			
			Tension	Shear	Box Qty.	Master Qty.
8561000	Plastic	3/4"	81	150	100	1200
* 8561100	Plastic Kit	3/4"	81	150	1	12
8571000	Zinc	3/4"	90	150	100	1200
* 8571100	Zinc Kit	3/4"	90	150	1	12

*Includes 50 #8 x 1-1/4" Screws and 50 Anchors

INSTALLATION

- 1 Place driving tool in anchor and puncture wallboard with anchor point.
- 2 Screw anchor clockwise applying forward pressure until head is flush to wall.
- 3 Place fixture over hole and tighten #8 or #10 sheet metal screw.

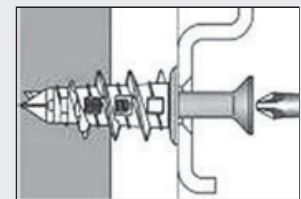
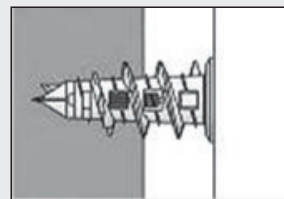
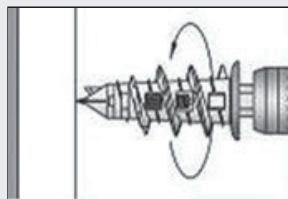

HOLLY

AVAILABLE MATERIALS

- Multi-legged sheet metal shell with machine screw, zinc plated

FEATURES/ADVANTAGES

- Light to medium loads under dead or variable conditions in a variety of hollow base materials
- Expanded, the shell is permanently installed and fixtures can be exchanged by removing and replacing the screw
- Drive Holly does not require a pre-drilled hole in gypsum board

CONSIDERATIONS

- Hollow construction only



ORDER DETAIL

Order Code	Size	Hole Diameter	Grip Range	Tension	Material Type	Shear	Minimum Wall Thickness	Box Qty.	Master Qty.
0120000	1/8" XS	5/16"	0" - 3/16"	—	Gypsum Wallboard	—	1/16"	100	3,000
0121000	1/8" SR	5/16"	1/8" - 5/8"	90	Gypsum Wallboard	165	1/8"	100	1,200
0122000	1/8" LR	5/16"	5/8" - 1-1/4"	130	Gypsum Wallboard	205	5/8"	100	800
0123000	1/8" XLR	5/16"	1-1/4" - 1-3/4"	260	Gypsum Wallboard	320	1-1/4"	100	800
0130000	3/16" SR	3/8"	1/8" - 3/4"	135	Gypsum Wallboard	300	1/8"	100	500
0131000	3/16" LR	3/8"	3/4" - 1-1/4"	260	Gypsum Wallboard	485	3/4"	100	500
0132000	3/16" XLR	3/8"	1-1/4" - 1-3/4"	300	Gypsum Wallboard	490	1-1/4"	100	300
0140000	1/4" SR	7/16"	1/8" - 5/8"	140	Gypsum Wallboard	300	1/8"	100	500
0141000	1/4" LR	7/16"	5/8" - 1-1/4"	165	Gypsum Wallboard	550	5/8"	50	400
0142000	1/4" XLR	7/16"	1-1/4" - 1-3/4"	200	Gypsum Wallboard	575	1-1/4"	50	400
Drive Holly									
0150000	1/8" XSD	DRIVE N/A	1/16" - 1/4"	—	Gypsum Wallboard	—	1/16"	100	1,200
0151000	1/8" SD	DRIVE N/A	1/8" - 1/2"	25	Gypsum Wallboard	90	1/8"	100	1,200
0152000	1/8" SLD	DRIVE N/A	1/8" - 3/4"	85	Gypsum Wallboard	175	1/8"	100	1,200

Setting Tool

0110000	Holly Setting Tool							1	—
---------	--------------------	--	--	--	--	--	--	---	---

INSTALLATION

- Drill hole through the base material same diameter as fastener.
- Clean hole of debris.
- Insert the fastener through the material and tap until head is flat against the wall surface.
- Turn screw with screwdriver until fastener is expanded. Can also be set using a Holly Setting Tool.
- Remove screw.
- Place fixture. Replace screw through fixture and tighten.

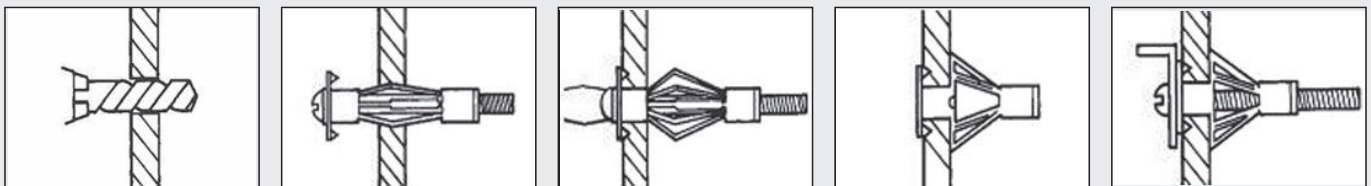

AVAILABLE MATERIALS

- Zinc diecast alloy

FEATURES/ADVANTAGES

- Medium to heavy loads
- Can be used in dead, variable, or vibratory conditions in all types of solid masonry
- Cannot be over-expanded, excellent near edge of slabs

APPROVALS/LISTINGS

- G.S.A. Spec A-A-1923A, CID TYPE 1
- Contact customer service for approvals



ORDER DETAIL

Order Code	Bolt Dia.	Hole Dia.	Shield Length	Box Qty.	Master Qty.
Short Shields					
3304000	1/4"	1/2"	1"	100	1200
3305000	5/16"	1/2"	1-1/4"	100	800
3306000	3/8"	5/8"	1-3/4"	50	400
3308000	1/2"	3/4"	2"	50	250
Long Shields					
3314000	1/4"	1/2"	1-1/2"	100	800
3315000	5/16"	1/2"	1-3/4"	100	500
3316000	3/8"	5/8"	2-1/2"	50	250
3318000	1/2"	3/4"	3"	50	150

INSTALLATION

- 1 Drill recommended hole to depth of shield.
- 2 Clean hole of debris.
- 3 Insert shield in hole and tap with hammer for proper positioning.
- 4 Place equipment over shield. Insert lag screw into shield and tighten.

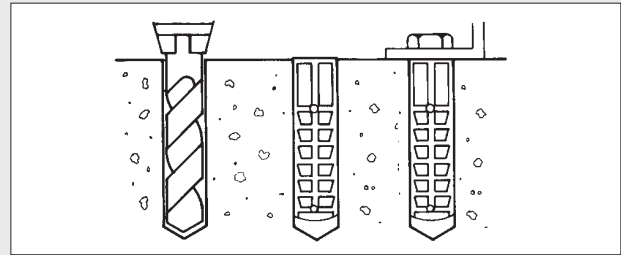

ZAP-IT®

AVAILABLE MATERIALS

Zinc Zap-It body with:

- Carbon steel nail, zinc plated
- Stainless steel nail



FEATURES/ADVANTAGES

- Required hole diameter equals anchor diameter
- Fast, easy installation
- Stainless steel nail and zinc anchor body allow for fastening in outdoor applications

CONSIDERATIONS

- Dead loads only
- Not recommended for eccentric loading

APPROVALS/LISTINGS

- G.S.A. Spec A-A-1925A, CID Type 1
- Contact customer service for approvals

ORDER DETAIL

Order Code	Stainless Steel	Anchor Diameter & Length	Hole Diameter	Embedment	Ultimate Tension 3000 PSI	Ultimate Shear 3000 PSI	Box Qty.	Master Qty.
3912000	—	3/16" x 7/8"	3/16"	5/8"	—	—	100	3,000
3914000	—	1/4" x 3/4"	1/4"	3/4"	750	1,516	100	800
3916000	3916SSO	1/4" x 1"	1/4"	3/4"	750	1,516	100	800
3920000	3920SSO	1/4" x 1-1/4"	1/4"	1"	1,000	1,516	100	800
3924000	—	1/4" x 1-1/2"	1/4"	1-1/4"	1,100	1,516	100	500
3928000	—	1/4" x 2"	1/4"	1-3/4"	1,400	1,516	100	500
3930000	—	1/4" x 3"	1/4"	1-3/4"	1,400	1,516	100	500

INSTALLATION

- 1 Drill hole to length of product selected.
- 2 Clean hole of debris.
- 3 Insert "Zap-It" through material, place in hole and tap nail until flush with head.

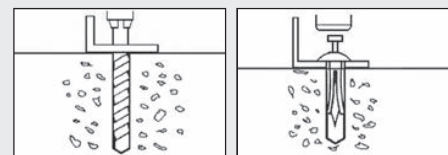

ADHESIVE

ANCHORING SYSTEMS

LIQUID ROC ADHESIVE COMPARISON

	LR 200 Single/Twin Tube	LR 300 Twin Tube	LR 700+ Single/Twin Tube	EP800 Single/Twin Tube	VMZ Internal Thread Injection	LR 300 Capsule	LR 300 Pouch
Cure Time (68°F)	45 min.	40 min.	1 hr.	5 hr.	1 hr.	10 min.	20 min.
Cure Temperature	23-104°F+	25-100°F+	14-104°F+	41 - 104°F+	23 - 104°F+	15-100°F+	15-100°F+
High Temperature Service	320°F	110°F	248°F	176°F	248°F	176°F	176°F
Shelf Life	18 months	9 months	18 months	24 months	18 months	24 months	18 months
Mix Ratio	Important	Important	Important	Important	Important	Important	Important
Weathering	Excellent	Fair	Good	Excellent	Good	Fair	Fair
Chemical Resistance	Excellent	Fair	Good	Excellent	Good	Fair	Fair
Shrinkage	<1/2%	4%	1/2%	<1/2%	1/2%	4%	4%

APPLICATION AND PRODUCT SELECTION GUIDE

Page No.	Types of Adhesive	Fastening Base Material						Application Criteria					Materials	Versions of Anchors	Characteristics	
		Concrete	Hard Natural Stone	Soft Natural Stone	Solid/Hollow Brick	Grout Filled Block	Hollow Concrete Block	Wood/Metal Gypsum/Plastic Foam Ins	In-place (through) Fastening	Immediate Loading	Flush Surface Removing	Dynamic Loading				Temp Resistant
HEAVY DUTY																
47	Liquid Roc 200	●	●	●	●	●	○					●	●	- Hybrid Urethane - Benzoyl Peroxide Hardener	- Threaded Rod - Rebar - Smooth Dowel - (Straight Cut)	Bonds to Hollow or Solid Masonry
49	Liquid Roc 300 Capsule	●	○			○						●	○	- Polyester Resin - Benzoyl Peroxide Hardener - Quartz Sand	- Threaded Rod - Rebar - (Chamfer Cut)	Mixes in hole with use of rotary hammer only
50	Liquid Roc 300 Pouch	●	○	○								●	○	- Polyester Resin - Benzoyl Peroxide Hardener	- Threaded Rod - Rebar - Smooth Dowel - (Straight Cut)	Bonds to Solid Masonry
51	Liquid Roc 300 Twin Tube	●	●	●	●	●	○					●	○	- Polyester Resin - Benzoyl Peroxide Hardener	- Threaded Rod - Rebar - Smooth Dowel - (Straight Cut)	Bonds to Hollow or Solid Masonry
52	VMZ Internal Thread Injection System	●	●	●		●						●		- Vinyl Ester Resin - Styrene Free	- Threaded Rod - Rebar - Internal Thread Insert	Bonds to Solid Masonry Low Odor
55	Liquid Roc 700+ Single/Twin Tube	●	●	●	●	●	○					●	○	- Acrylic Base - Benzoyl Peroxide Hardener	- Threaded Rod - Rebar - Smooth Dowel - (Straight Cut)	Bonds to Hollow or Solid Masonry
53	EP 800	●	●	●	●	●	○					●	○	- 2-component reaction resin mortar based on a pure epoxy - Compound mortar Bcomponent (hardener)	- Threaded Rod - Rebar - Smooth Dowel - (Straight Cut)	Bonds to Hollow or Solid Masonry

KEY ● VERY SUITABLE ○ MAY BE SUITABLE PER APPLICATION

LIQUID ROC® 200



10 Oz. Single Tube



28 Oz. Twin Tube

AVAILABLE MATERIALS

- Twin/Single Tube-hybrid urethane resin base, benzoyl peroxide hardener
- Square cut rods-A307 steel, zinc plated. Other sizes, materials and finishes available

FEATURES/ADVANTAGES

- Multi temperature formulation is suitable for use down to 23°F (-5°C)
- Fast cure time even at the coldest temperatures
- Styrene free formula is low odor and VOC free
- Ideal for bonding a wide variety of material to concrete
- In service temperatures of up to 320°F (160°C).
- Extremely high chemical resistance.
- Certified for drinking water applications to NSF Standard 61.
- Nozzle provided for dispensing

CURE TIME

Concrete Temperature	Gel Time	Cure Time
23° F	50 minutes	5 hours
32° F	25 minutes	3-1/2 hours
50° F	10 minutes	1 hour
86° F	3 minutes	30 minutes

APPROVALS/LISTINGS

- ACI 318 Category 1 for cracked concrete
- ICC ESR - 4252
- Contact customer service for approvals / listings for state DOT's

CONSIDERATIONS

- 18 month shelf life



ORDER DETAIL

Order Number	Description	Size	Quantity
7900010	Single Tube	10 oz.	12
7900028	Twin Tube	28 oz.	8

LOAD AND PERFORMANCE DATA

Anchor Size	3/8"	1/2"	5/8"	3/4"	7/8"	1"	1 1/4"							
Effective emb.	2 3/8"	7 1/2"	2 3/4"	10"	3 1/8"	12 1/2"	3 1/2"	15"	3 1/2"	17 1/2"	4"	20"	5"	25"
Characteristic Tension - Cracked														
2500 psi	2,022 lbs	6,968 lbs	2,520 lbs	11,946 lbs	3,052 lbs	19,479 lbs	3,618 lbs	31,313 lbs	3,618 lbs	40,447 lbs	4,420 lbs	49,417 lbs	6,177 lbs	69,063 lbs
4000 psi	2,313 lbs	7,266 lbs	3,187 lbs	12,521 lbs	3,861 lbs	20,416 lbs	4,576 lbs	31,313 lbs	4,576 lbs	43,313 lbs	5,591 lbs	56,813 lbs	7,814 lbs	84,241 lbs
6500 psi	2,428 lbs	7,266 lbs	3,615 lbs	13,144 lbs	4,921 lbs	21,188 lbs	5,833 lbs	31,313 lbs	5,833 lbs	43,313 lbs	7,127 lbs	56,813 lbs	9,960 lbs	88,432 lbs
Characteristic Tension - Uncracked														
2500 psi	2,855 lbs	7,266 lbs	3,557 lbs	13,303 lbs	4,309 lbs	21,188 lbs	5,107 lbs	31,313 lbs	5,107 lbs	43,313 lbs	6,240 lbs	56,813 lbs	8,721 lbs	90,844 lbs
4000 psi	3,611 lbs	7,266 lbs	4,499 lbs	13,303 lbs	5,450 lbs	21,188 lbs	6,460 lbs	31,313 lbs	6,460 lbs	43,313 lbs	7,893 lbs	56,813 lbs	11,031 lbs	90,844 lbs
6500 psi	4,603 lbs	7,266 lbs	5,736 lbs	13,303 lbs	6,948 lbs	21,188 lbs	8,235 lbs	31,313 lbs	8,235 lbs	43,313 lbs	10,062 lbs	56,813 lbs	14,062 lbs	90,844 lbs
Characteristic Shear														
Effective emb.	3 1/2"	4 1/2"	5"	6 1/2"	8"	10"	11"							
2500 psi	3,149 lbs	6,916 lbs	9,208 lbs	14,233 lbs	19,900 lbs	28,400 lbs	32,791 lbs							
4000 psi	3,149 lbs	6,916 lbs	11,018 lbs	16,305 lbs	22,506 lbs	29,526 lbs	41,478 lbs							

The above loads are based on a temperature range of max short term 104°F & max long term 75°F, hammer drilled holes that are dry, supplemental reinforcement present and for a single anchor design. No reductions have been taken for edge distance or anchor spacing. Verify that strength of the steel used is capable of supporting the desired load for each application.

LIQUID ROC® 200

USAGE INSTRUCTIONS - CONCRETE

MAC: Cleaning for hole diameter d0 3/4" and hole depth h0 10dS (uncracked concrete only!)

1. Hammer drill a hole into the base material to the diameter and embedment depth required by the selected anchor.
- 2a. Starting from the bottom or the back of the drilled hole, blow the hole clean by a hand pump a minimum of four times
- 2b. Check the brush diameter. Brush the hole with an appropriate sized wire brush > db, min a minimum of four times in a twisting motion. If the bottom of the drilled hole is not reached with the brush, a brush extension must be used.
- 2c. Finally blow the hole clean again with a hand pump a minimum of four times.

CAC: Cleaning for all hole diameter in uncracked and cracked concrete

- 2a. Starting from the bottom or back of the hole, blow the hole clean with compressed air (min. 90 psi) a minimum of two times until return air stream is free of noticeable dust. If the bottom of the drilled hole is not reached an extension must be used.
- 2b. Check the brush diameter. Brush the hole with an appropriate sized wire brush > db, min a minimum of two times in a twisting motion. If the bottom of the drilled hole is not reached with the brush, a brush extension must be used.
- 2c. Finally blow the hole clean again with compressed air (min. 90 psi) a minimum of two times until return air stream is free of noticeable dust. If the bottom of the drilled hole is not reached an extension must be used.

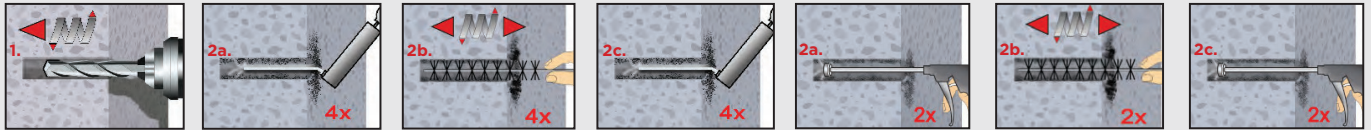

After cleaning, the hole has to be protected against re-contamination in an appropriate way, until dispensing the adhesive in the hole. If necessary, the cleaning has to be repeated directly before dispensing the adhesive. In water-filled hole applications, the water must not be allowed to re-enter the hole.



7500100
Caulking Gun for 10 oz. Single Tube



7521096
Pneumatic Dispensing Tool
for 28 oz. Twin Tube

7521019
Replacement Nozzle for 10 oz. Single Tube

7521035
Mixer Replacement Nozzle for
28 oz Twin Tube

7521095
Manual Dispensing Tool for
28 oz. Twin Tube



LIQUID ROC® 300 CAPSULE

AVAILABLE MATERIALS

- Capsules – polyester resin base, quartz sand, benzoyl peroxide hardener
- Chamfer cut rods – A307 steel, zinc plated. Other sizes, materials and finishes available upon request



FEATURES/ADVANTAGES

- Pre-measured adhesive
- No expensive dispensing tools
- Sand and aggregate mixture is closest to natural concrete

CONCERNS

- Hole must be of correct diameter and depth
- Do not use overhead
- Must use chamfer cut or chisel pointed rod
- 24 month shelf life
- For short term loading only

APPROVALS/LISTINGS

- Contact customer service for approvals/listings for state D.O.T's

LIQUID ROC 300 CAPSULE ANCHORS

Anchor Diameter	Hole Diameter	Embedment Depth	Capsules Required
3/8"	7/16"	3-1/2"	(1) 3/8"
3/8"	7/16"	5-1/4"	(2) 3/8"
3/8"	7/16"	7"	(2) 3/8"
1/2"	9/16"	4-1/2"	(1) 1/2"
1/2"	9/16"	6-3/4"	(1) 3/8" & (1) 1/2"
1/2"	9/16"	9"	(2) 1/2"
5/8"	11/16"	5"	(1) 5/8"
5/8"	11/16"	7-1/2"	(1) 1/2" & (1) 5/8"
5/8"	11/16"	10"	(2) 5/8"
3/4"	7/8"	6-1/2"	(1) 3/4"
3/4"	7/8"	9-3/4"	(1) 5/8" & (1) 3/4"
3/4"	7/8"	13"	(2) 3/4"
7/8"	1"	7-1/2"	(1) 7/8"
7/8"	1"	11-1/4"	(2) 3/4"
7/8"	1"	15"	(2) 7/8"
1"	1-1/8"	8-1/2"	(1) 1"
1"	1-1/8"	12-3/4"	(1) 3/4" & (1) 1"
1"	1-1/8"	17"	(2) 1"
1-1/4"	1-3/8"	7-1/4"	(2) 3/4"
1-1/4"	1-3/8"	11"	(1) 3/4" & (1) 1"

CURE TIME

Concrete Temperature	Time
Over 68°F.	10 min.
50° to 68°F.	20 min.
32° to 50°F.	1 hr.
23° to 32°F.	5 hrs.

ORDER DETAIL

Capsule Order Code	Chamfer Cut Rod (2)	Anchor Size	Hole Dia.	Impact Socket Size	Min. Embedment	Ultimate Tensile & Shear Loads in Lbs.* Concrete Strength (P.S.I.)				Capsule		Rod	
						3000 P.S.I.		5000 P.S.I.		Box Quantity	Master Quantity	Box Quantity	Master Quantity
						Tension	Shear	Tension	Shear				
3206000	3206020	3/8" x 5"	7/16"	9/16"	3-1/2"	7,800	3,983	7,420	3,983	10	560	10	80
3208000	3208025	1/2" x 6-1/4"	9/16"	3/4"	4-1/2"	9,820	7,323	15,720	7,323	10	560	10	50
3210000	3210030	5/8" x 7-1/2"	11/16"	15/16"	5"	19,360	11,757	20,180	11,757	10	560	10	50
3212000	3212041	3/4" x 10-1/4"	7/8"	1-1/8"	6-1/2"	23,880	17,257	30,060	17,257	10	60	6	12
3214000	3214047	7/8" x 11-3/4"	1"	1-5/16"	7-1/2"	23,880	24,338	39,280	24,338	10	60	6	12
3216000	3216047	1" x 11-3/4"	1-1/8"	1-1/2"	8-1/2"	38,280	29,128	47,900	29,128	5	60	6	12

*Load values based on A-193, B7 Rods. (2) Rods may be cut to order Metric sizes available upon request

INSTALLATION

- 1 Drill hole to correct size and depth using rotary-hammer.
- 2 Remove dust and rubble from the hole with compressed air, a brush and water. Excess water must be removed although the hole may be damp.
- 3 Insert the capsule in the hole, either end first.
- 4 Double nut the threaded rod, and insert the chamfered stud into the hole to break the capsule. Under power, hammer drill the chamfered stud to full depth, maintaining power for two or three seconds after the chamfered stud bottoms.
- 5 Promptly and carefully remove the drive socket from the stud, leaving it undisturbed through the prescribed curing time consistent with onsite temperature.

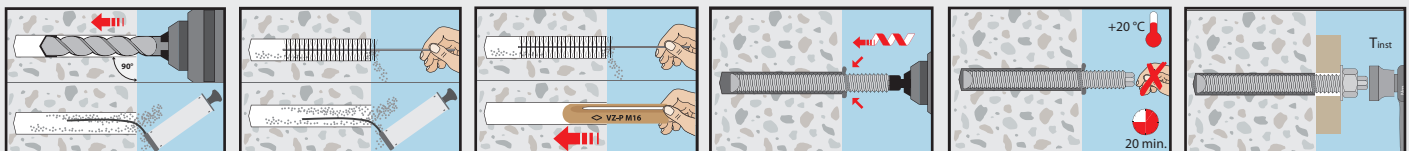

LIQUID ROC® 300 POUCH

AVAILABLE MATERIALS

- Pouch - polyester resin base, benzoyl peroxide hardener
- Square-cut rods- A307 steel, zinc plated. Other sizes, materials and finishes available upon request



FEATURES/ADVANTAGES

- No dispensing tools needed
- Pre-measured adhesive
- No messy mixing
- Will cure below freezing
- Pourable consistency

CONSIDERATIONS

- Cannot be used in horizontal or overhead holes
- Must be used within 20 minutes after mixing
- 18 month shelf life
- For short term loading only

APPROVALS/LISTINGS

- Contact customer service for approvals/listings for state D.O.T.'s



CURE TIME

Concrete Temperature	Time	Concrete Temperature	Time
Over 80°F.	10-15 min.	48° to 38°F.	2 hrs.
80° to 68°F.	15-20 min.	38° to 28°F.	4 hrs.
68° to 58°F.	20-30 min.	28° to 18°F.	6 hrs.
58° to 48°F.	30-60 min.	Below 18°F.	24 hrs.

SQUARE CUT ROD

Order Code	Size	Box Quantity	Master Quantity
3106032	3/8" x 8"	10	50
3106048	3/8" x 12"	10	20
3108032	1/2" x 8"	10	50
3108048	1/2" x 12"	10	20
3110032	5/8" x 8"	10	50
3110048	5/8" x 12"	10	20
3112032	3/4" x 8"	10	50
3112048	3/4" x 12"	10	20

ORDER DETAIL

Ultimate Tensile & Shear Loads in Lbs.*
Concrete Strength (P.S.I.)

Pouch Order Code	Square Cut Rod Order Code	Size	Hole Diameter	Minimum Embedment	3000 P.S.I. Tension	Shear	5000 P.S.I. Tension	Shear	Rod Box Quantity	Rod Master Quantity	
7511008 5.5 fl. oz 5/Box	3106032	3/8" x 8"	7/16"	3-1/2"	6,925	3,780	8,008	3,780	10	50	
	3106048	3/8" x 12"	7/16"	3-1/2"	6,925	3,780	8,008	3,780	10	20	
	3108032	1/2" x 8"	9/16"	4-1/2"	10,650	6,840	11,319	6,840	10	50	
	3108048	1/2" x 12"	9/16"	4-1/2"	10,650	6,840	11,319	6,840	10	20	
	3110032	5/8" x 8"	11/16"	5-1/2"	19,225	11,570	20,125	11,570	10	50	
	3110048	5/8" x 12"	11/16"	5-1/2"	19,225	11,570	20,125	11,570	10	20	
	3112032	3/4" x 8"	7/8"	6-1/2"	20,975	17,860	21,940	17,860	10	50	
	3112048	3/4" x 12"	7/8"	6-1/2"	20,975	17,860	21,940	17,860	10	20	
	**	**	7/8"	1"	7-1/2"	25,300	21,670	31,156	21,670	-	-
	**	**	1"	1-1/8"	8-1/2"	26,425	26,730	31,454	26,730	-	-

*Load values based on A-193, B7 Rods ** Special, Made to Order

INSTALLATION

- 1 Drill hole to correct size and depth using rotary-hammer.
- 2 Remove dust and rubble from the hole with compressed air, brush and water. Excess water must be removed although hole may be damp. Hold each end of the pouch and pull firmly to remove dividers. Mix thoroughly in pouch until color is uniform. Do not use excessive pressure or puncture pouch while mixing.
- 3 Cut corner and fill hole 2/3 full.
- 4 Insert stud turning slowly by hand.
- 5 Leave it undisturbed through prescribed curing time consistent with the on-site temperature.

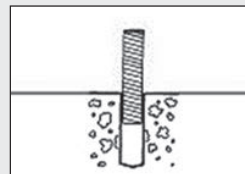
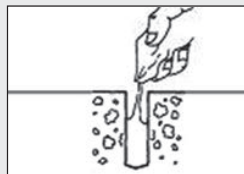

LIQUID ROC® 300 TWIN TUBE

AVAILABLE MATERIALS

- Twin Tube - polyester resin base, benzoyl peroxide hardener
- Square cut rods - A307 steel, zinc plated. Other sizes, materials and finishes available upon request

FEATURES/ADVANTAGES

- Pre-measured adhesive
- Easy to use and can be saved for re-use
- Nozzle included
- Works in hollow applications
- Can be used with screen tubes



CONSIDERATIONS

- 9 month shelf life
- For short term loading only

APPROVALS/LISTINGS

- Contact customer service for approvals/listings for state D.O.T.'s

Anchor Type	Ultimate Loads in Lbs. Unreinforced Brick Wall		
	Drill Diameter	Embedment	Average Load (lbs)
3/4" shear	1"	8"	7056 shear
3/4" combo 22-1/2"	1"	12-1/2"	8830 tension
5/8" combo	1" / 5/8"	8" / 13"	9292 shear

CURE TIME

Concrete Temperature	Time
Over 80°F.	20-30 min.
80° to 68°F.	30-40 min.
68° to 58°F.	40-50 min.
58° to 48°F.	60 min.
48° to 38°F.	2 hrs.
38° to 28°F.	4 hrs.

WIRE MESH SCREEN

Order Code	Description	O.D.
7706924	3/8"x 6"	1/2"
7706940	3/8"x 10"	1/2"
7708924	1/2"x 6"	5/8"
7708940	1/2"x 10"	5/8"
7710924	5/8"x 6"	3/4"
7710940	5/8"x 10"	3/4"
7712924	3/4"x 6"	1"
7712940	3/4"x 10"	1"



7521095
Manual Tool for 28 oz. Twin Tube



7521096
Pneumatic Gun for 28 oz. Twin Tube

7521020
Replacement Nozzle

ORDER DETAIL

Ultimate Tensile & Shear Loads in Lbs.*
Concrete Strength (P.S.I.)

Twin Tube Order Code	Sq. Cut Rod Diameter	Hole Diameter	Minimum Embedment	2000 P.S.I.		4000 P.S.I.		Grouted Masonry Block**		Hollow Masonry Block**	
				Tension	Shear	Tension	Shear	Tension	Shear	Tension	Shear
7521041 28 fl.oz. w/Nozzle 5/Box	3/8"	1/2"	3-1/2"	4,720	6,133	5,920	6,133	4,562	5,997	1,007	2,214
	1/2"	5/8"	4-1/2"	9,067	8,880	9,067	9,520	5,541	9,015	1,071	1,446
	5/8"	3/4"	5-1/2"	11,387	12,160	14,427	14,053	7,222	11,213	858	2,830
	3/4"	1"	6"	—	—	—	—	—	—	1,458	2,249
	7/8"	1"	7-1/2"	18,213	19,360	19,973	20,000	9,561	10,993	—	—
	1"	1-1/8"	8-1/2"	24,107	24,640	26,507	26,827	—	—	—	—

*Load values based on A-193, B7 Rods ** Concrete masonry units meet ASTM C90, Grade N, Type 1

USAGE INSTRUCTIONS - CONCRETE

MAC: Cleaning for hole diameter d0 3/4" and hole depth h0 10ds (uncracked concrete only!)

1. Hammer drill a hole into the base material to the diameter and embedment depth required by the selected anchor.
- 2a. Starting from the bottom or the back of the drilled hole, blow the hole clean by a hand pump a minimum of four times
- 2b. Check the brush diameter. Brush the hole with an appropriate sized wire brush > db, min a minimum of four times in a twisting motion. If the bottom of the drilled hole is not reached with the brush, a brush extension must be used.
- 2c. Finally blow the hole clean again with a hand pump a minimum of four times.

CAC: Cleaning for all hole diameter in uncracked and cracked concrete

- 2a. Starting from the bottom or back of the hole, blow the hole clean with compressed air (min. 90 psi) a minimum of two times until return air stream is free of noticeable dust. If the bottom of the drilled hole is not reached an extension must be used.
- 2b. Check the brush diameter. Brush the hole with an appropriate sized wire brush > db, min a minimum of two times in a twisting motion. If the bottom of the drilled hole is not reached with the brush, a brush extension must be used.
- 2c. Finally blow the hole clean again with compressed air (min. 90 psi) a minimum of two times until return air stream is free of noticeable dust. If the bottom of the drilled hole is not reached an extension must be used.

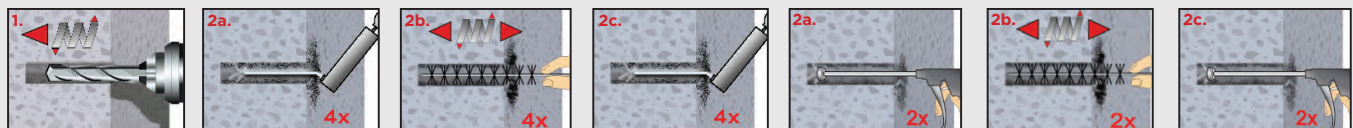

After cleaning, the hole has to be protected against re-contamination in an appropriate way, until dispensing the adhesive in the hole. If necessary, the cleaning has to be repeated directly before dispensing the adhesive. In water-filled hole applications, the water must not be allowed to re-enter the hole.

VMZ INTERNAL THREAD INJECTION SYSTEM

AVAILABLE MATERIALS

Carbon Steel Zinc Plated

FEATURES/ADVANTAGES

- Can be installed using a construction grade single tube tool
- The fixture is easily removed
- Closer anchor spacing and edge distance than with drop-in anchors
- Rated for cracked or un-cracked concrete
- Eliminates trip hazard by using finished head bolts
- Ultimate loads are derived from installation in un-cracked concrete

CONSIDERATIONS

- 18 month shelf life

APPLICATIONS:

Heavy duty anchoring where the use of internal thread is required and/or anchor spacing and edge distance requirements are closer than those needed for drop-in anchor: Steel structures, brackets, railings, posts, columns, ladders, gates, etc.



M28252601

VMZ Adhesive Single Tube Only

ORDER DETAIL

Order Code Carbon Steel	Anchor Size	Min Hole Depth (Inch)	Thread Length (Inch)	Embed Depth (Inch)	Install Torque (ft-lbs)	Drill Diameter (Inch)	4000 psi Tension* (lbf)	Concrete Shear* (lbf)	Anchors/ Cartridge
301415I	1/4"	1-5/8	1/2	1-5/8	6	3/8	3344	1810	123
305162I	5/16"	2-1/2	3/4	2-3/8	7	1/2	7424	3383	53.7
303831I	3/8"	3	1	2-3/4	11	9/16	9255	4980	42.6
301241I	1/2"	3-3/4	1	3-1/2	18	3/4	15,215	8881	20.1
305861I	5/8"	6-1/4	1-1/2	5-7/8	37	1	32,334	16,799	5.4
303471I	3/4"	6-5/8	1-1/2	6-1/8	59	1	30,100	23,780	9.5

* Ultimate load values are based on using VMZ adhesive with inserts.
Be sure to use a bolt with suitable tensile strength to attain loads.

*Also available in metric 316 Stainless Steel

Base Material Temperature	Gel Time	Cure Dry Hole	Cure Wet Hole
-5 C/23 F	1.5 Hr	6 Hr	12 Hr
0 C/32 F	45 Min	3 Hr	6 Hr
5 C/41 F	20 Min	2 Hr	4 Hr
10 C/50 F	12 Min	1.3 Hr	2.5 Hr
20 C/68 F	6 Min	45 Min	1.5 Hr
30 C/86 F	4 Min	25 Min	50 Min
35 C/95 F	2 Min	20 Min	40 Min
40 C/104 F	1.5 Min	15 Min	30 Min

INSTALLATION

- 1 Select the correct diameter drill bit and drill the hole to the required hole depth.
- 2 Remove the debris from the hole using compressed air and a brush.
- 3 Inject VMZ adhesive into the hole starting at the bottom and working outward to avoid air pockets.
- 4 Place the anchor in the hole using a twisting motion until it is flush with the concrete.
- 5 Do not disturb the anchor until full cure has been reached as indicated by the table above.
- 6 Clear excess adhesive from the hole opening using a chisel before removing rubber plug.
- 7 Place fixture over the hole and start the bolt until finger tight.
- 8 Tighten bolt to appropriate torque to complete the fastening.

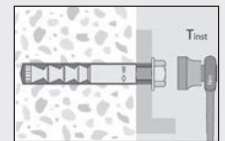
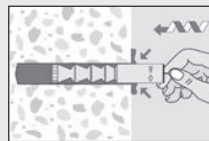
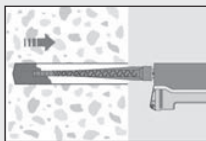
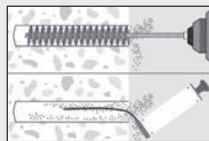
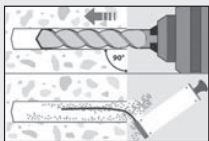

EP800 PURE EPOXY

AVAILABLE MATERIALS

- Pure Epoxy
- 1:1 Ratio

FEATURES/ADVANTAGES

- Compliant with the newest design codes
- OSHA compliant
- Qualified for seismic design (Category A-F)
- Suitable for heavy anchoring and post-installed rebar connection
- High chemical resistance
- Low odor
- High bending and pressure strength
- Maximum performance in concrete
- The cartridge, can be reused up to the end of the shelf life by replacing the static mixer or resealing the cartridge with the sealing cap



9.5 fl.oz (280ml)
Single-tube

20.5 fl.oz (610ml)
Twin-tube

CONSIDERATIONS

- 24 month shelf life

APPROVALS/LISTINGS

- ICC-ES (ESR-4901) cracked concrete
- Tested to AC308 & ACI355.4
- LEED Attestation (VOC)
- DOT Approvals/Listings
- Application in dry, wet, submerged concrete or water-filled boreholes, overhead application, etc.
- Diamand Core Bit

INSTALLATION

Drilling of the bore hole (HD, CD; HDB) - ESR-4901

Precaution: Wear suitable eye and skin protection. Avoid inhalation of dusts during drilling and/or removal. (see dust extraction equipment by Chemofast to minimize dust emissions)

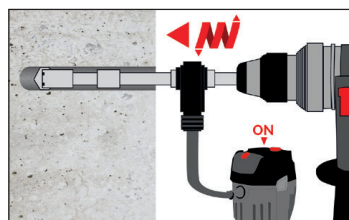
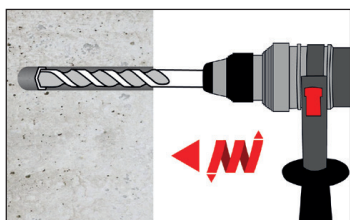

1. Drill a hole into the base material with a hammer drill tool to the size and embedment required by the selected steel hardware element (see Table on page 12). The tolerances of the carbide drill bit must meet the requirements of ANSI Standard B212.15. For bore holes drilled with the Chemofast hollow drill bit system (consisting of Heller Duster Expert drill bits and a Class M vacuum with air flow 150 m³/h resp. 42 l/s resp. 90 cfm; the vacuum must be on!) no further cleaning is required go to Step 3, otherwise to Step 2a for MAC or CAC hole cleaning instructions.

Attention! Standing water must be removed (e.g. vacuum, compressed air, etc.) prior to cleaning.

CAC: Cleaning (dry, water saturated and water-filled) for all drill hole diameter in uncracked and cracked concrete

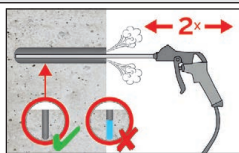

2a.

Starting from the bottom or back of the anchor hole, blow the hole clean with compressed air (min. 6 bar / 90 psi) a minimum of two times, until return air stream is free of noticeable dust. If the back of the drilled hole is not reached an extension shall be used.

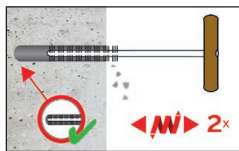

2b.

Determine brush diameter (see Table on page 12) for the drilled hole. Brush the hole with the selected wire brush a minimum of two times (2x). A brush extension (supplied by Chemofast Anchoring GmbH) must be used for drill hole depth > 6" (150 mm). The wire brush diameter must be checked periodically during use ($\phi_{brush} > d_{b,min}$ see Table on page 12). The brush should resist insertion into the drilled hole - if not the brush is too small and must be replaced with the proper brush diameter. If the back of the drilled hole is not reached a brush extension shall be used.

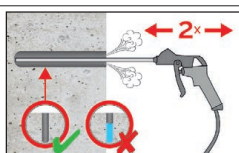

2c.

Finally blow the hole clean again with compressed air (min. 6 bar / 90 psi) a minimum of two times, until return air stream is free of noticeable dust. If the back of the drilled hole is not reached an extension shall be used. When finished the hole should be clean and free of dust, debris, ice, grease, oil or other foreign material.

EP800 PURE EPOXY CONTINUED

INSTALLATION

UWC: Cleaning (submerged) for all bore hole diameter in uncracked and cracked concrete

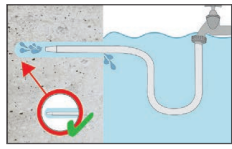

2a.

Starting from the bottom or back of the bore hole, rinse/flush the hole clean until clean water comes out. If the back of the drilled hole is not reached an extension shall be used.

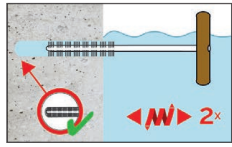

2b.

Determine brush diameter (see Table on page 12) for the drilled hole. Brush the hole with the selected wire brush a minimum of two times (2x). A brush extension (supplied by Chemofast Anchoing GmbH) must be used for drill hole depth > 6" (150 mm). The wire brush diameter must be checked periodically during use ($d_{brush} > d_{b,min}$ see Table on page 12). The brush should resist insertion into the drilled hole - if not the brush is too small and must be replaced with the proper brush diameter. If the back of the drilled hole is not reached a brush extension shall be used.

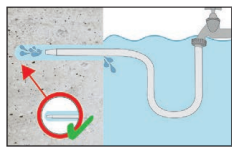

2c.

Finally, starting from the bottom or back of the bore hole, rinse/flush the hole clean until clean water comes out. If the back of the drilled hole is not reached an extension shall be used.

After cleaning, the bore hole has to be protected against re-contamination in an appropriate way, until dispensing the mortar in the bore hole. If necessary, the cleaning has to be repeated directly before dispensing the mortar. In-flowing water must not contaminate the bore hole again.

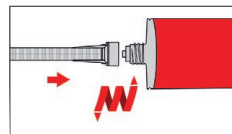

3.

Check adhesive expiration date on cartridge label. Do not use expired product. Review Safety Data Sheet (SDS) before use. For the permitted range of the base material and cartridge temperature see Table on page 4. Attach a supplied mixing nozzle to the cartridge. Do not modify the mixer in any way and make sure the mixing element is inside the nozzle. Load the cartridge into the correct dispensing tool.

Note: Always use a new mixing nozzle with new cartridges of adhesive and also for all work interruptions exceeding the published gel (working) time of the adhesive.

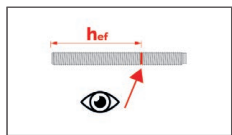

4.

Prior to inserting the anchor rod or rebar into the filled drilled hole, the position of the embedment depth has to be marked on the anchor. Verify anchor element is straight and free of surface damage.

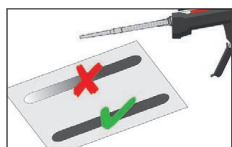

5.

Adhesive must be properly mixed to achieve published properties. Prior to dispensing adhesive into the drilled hole, separately dispense at least three full strokes of adhesive through the mixing nozzle until the adhesive is a consistent gray or red color. Review and note the published working and cure times (see Table on page 4) prior to injection of the mixed adhesive into the cleaned anchor hole.

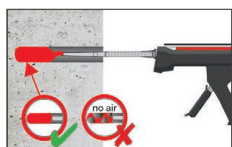

6.

Fill the cleaned hole approximately two-thirds full with mixed adhesive starting from the bottom or back of the anchor hole. Slowly withdraw the mixing nozzle as the hole fills to avoid creating air pockets or voids. If the bottom or back of the anchor hole is not reached with the mixing nozzle only an extension tube supplied by Chemofast Anchoing GmbH (Cat# 16009 or Cat# 16004) must be used with the mixing nozzle.

LIQUID ROC® 700+

AVAILABLE MATERIALS

- Twin/Single Tube-acrylic resin base, benzoyl peroxide hardener
- Square cut rods-A307 steel, zinc plated. Other sizes, materials and finishes available

FEATURES/ADVANTAGES

- Multi temperature formulation is suitable for use down to 14°F (-10°C)
- Fast cure time even at the coldest temperatures
- Styrene free formula is low odor and VOC free
- Nozzle provided for dispensing

APPROVALS/LISTINGS

- ACI 318 Category 1 for cracked concrete
- ICC ESR - 4004
- Contact customer service for approvals / listings for state DOT's

CONSIDERATIONS

- 18 month shelf life



10 Oz. Single Tube



28 Oz. Twin Tube



CURE TIME

Concrete Temperature	Gel Time	Cure Time
14° F (-10° C)	60 minutes	15 Hours
41° F (5° C)	20 minutes	2 Hours
59° F (15° C)	7 minutes	1 Hour
86° F (30° C)	2 minutes	20 Minutes

ORDER DETAIL

Order Number	Description	Size	Quantity
7620010	Single Tube	10 oz.	12
7620028	Twin Tube	28 oz.	4

LOAD AND PERFORMANCE DATA

Anchor Size	3/8"	1/2"	5/8"	3/4"	7/8"	1"	1 1/4"							
Effective emb.	2 3/8"	4 1/2"	2 3/4"	6"	3 1/8"	7 1/2"	3 1/2"	9"	3 1/2"	10 1/2"	4"	12"	5"	15"

Characteristic Tension - Cracked

2500 psi	na	na	1,834 lbs	4,002 lbs	2,713 lbs	6,511 lbs	3,618 lbs	9,376 lbs	3,618 lbs	12,762 lbs	4,420 lbs	16,871 lbs	6,177lbs	26,361 lbs
4000 psi	na	na	1,950 lbs	4,254 lbs	2,884 lbs	6,922 lbs	3,876 lbs	9,967 lbs	4,522 lbs	13,566 lbs	5,591 lbs	17,934 lbs	7,814 lbs	28,022 lbs

Characteristic Tension - Uncracked

2500 psi	1,978 lbs	3,747 lbs	3,053 lbs	6,662 lbs	4,309 lbs	10,410 lbs	5,107 lbs	14,990 lbs	5,107 lbs	20,403 lbs	6,240 lbs	23,984 lbs	8,721 lbs	29,578 lbs
4000 psi	2,102 lbs	3,984 lbs	3,246 lbs	7,082 lbs	4,611 lbs	11,065 lbs	6,197 lbs	15,934 lbs	6,460 lbs	21,688 lbs	7,893 lbs	25,495 lbs	10,480 lbs	31,441 lbs

Characteristic Shear

Effective emb.	3 1/2"	4 1/2"	5"	6 1/2"	8"	10"	11"
2500 psi	3,778 lbs	6,918 lbs	9,284 lbs	14,765 lbs	20,160 lbs	28,174 lbs	32,505 lbs
4000 psi	3,778 lbs	6,918 lbs	11,018 lbs	16,282 lbs	22,522 lbs	29,542 lbs	41,115 lbs

The above loads are based on a temperature range of max short term 104°F & max long term 75°F, hammer drilled holes that are dry, supplemental reinforcement present and for a single anchor design. No reductions have been taken for edge distance or anchor spacing. Verify that strength of the steel used is capable of supporting the desired load for each application.

ACCESSORIES

7500100
Caulking Gun for 10 oz. Single Tube



7521020
Replacement Nozzle for 10 oz. Single Tube

7521035
Replacement Nozzle for 28 oz. Twin Tube



7521096
Pneumatic Dispensing Tool for 28 oz. Twin Tube



7521095
Manual Dispensing Tool for 28 oz. Twin Tube



LIQUID ROC® 700+ CONTINUED

USAGE INSTRUCTIONS - CONCRETE

MAC: Cleaning for hole diameter d0 3/4" and hole depth h0 10ds (uncracked concrete only!)

1. Hammer drill a hole into the base material to the diameter and embedment depth required by the selected anchor.
- 2a. Starting from the bottom or the back of the drilled hole, blow the hole clean by a hand pump a minimum of four times
- 2b. Check the brush diameter. Brush the hole with an appropriate sized wire brush > db, min a minimum of four times in a twisting motion. If the bottom of the drilled hole is not reached with the brush, a brush extension must be used.
- 2c. Finally blow the hole clean again with a hand pump a minimum of four times.

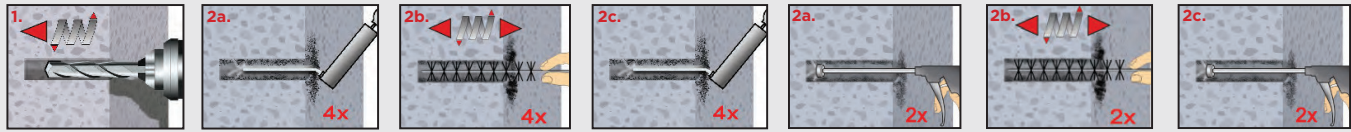

After cleaning, the hole has to be protected against re-contamination in an appropriate way, until dispensing the adhesive in the hole. If necessary, the cleaning has to be repeated directly before dispensing the adhesive. In water-filled hole applications, the water must not be allowed to re-enter the hole.

CAC: Cleaning for all hole diameter in uncracked and cracked concrete

- 2a. Starting from the bottom or back of the hole, blow the hole clean with compressed air (min. 90 psi) a minimum of two times until return air stream is free of noticeable dust. If the bottom of the drilled hole is not reached an extension must be used.
- 2b. Check the brush diameter. Brush the hole with an appropriate sized wire brush > db, min a minimum of two times in a twisting motion. If the bottom of the drilled hole is not reached with the brush, a brush extension must be used.
- 2c. Finally blow the hole clean again with compressed air (min. 90 psi) a minimum of two times until return air stream is free of noticeable dust. If the bottom of the drilled hole is not reached an extension must be used.

ADHESIVE VOLUME ESTIMATING GUIDE

Type Package	Liquid Roc 200 Single Tube	Liquid Roc 200 Twin Tube	Liquid Roc 300 Pouch	Liquid Roc 300 Twin Tube	VMZ Internal Thread Injection System	Liquid Roc 700+ Single Tube	Liquid Roc 700+ Twin Tube	EP800
Net Contents	10 fl. oz.	28 fl. oz.	5.5 fl. oz.	28 fl. oz.	10 fl. oz.	10 fl. oz.	28 fl. oz.	9.5 fl. oz. 20.9 fl. oz.
Useable Vol.	15 cu. in.	45 cu. in.	10 cu. in.	45 cu. in.	15 cu. in.	15 cu. in.	45 cu. in.	13 cu. in. 34 cu. in.
Rod Diameter	Linear inches of embedment into solid base material							
3/8"	63	133	105	312	63	63	133	91 237
1/2"	45	95	75	225	45	45	95	65 169
5/8"	35	73	38	172	35	35	73	50 130
3/4"	28	58	30	137	28	28	58	40 104
7/8"	23	49	25	115	23	23	49	33 87
1"	19	40	21	92	19	19	40	27 71
1-1/4"	14	30	16	71	14	14	30	20 54
Rod Diameter	Linear inches of embedment using screens into hollow base material							
3/8"	-	-	-	296	-	-	-	-
1/2"	-	-	-	172	-	-	-	-
5/8"	-	-	-	112	-	-	-	-
3/4"	-	-	-	62	-	-	-	-

ENGINEERING DATA

HOW TO SPECIFY

- 1 Select anchor diameter based on loading requirements.
- 2 Determine thickness of material to be anchored (if grout or shimming is to be used between material and concrete surface, add thickness of grout/shims to thickness of material to obtain total thickness of material to be anchored.)
- 3 Select anchor length that will satisfy total thickness of material, head clearance and embedment of anchor diameter selected.

REDUCTION FACTORS

Tension		Shear		
Spacing (S) and Edge Dist. (M)	Factor (F)	Spacing (S) and Edge Dist. (M)	Direction of load	Factor (F)
S min. = 0.50S	0.7	S min. = 0.50S	toward edge	0.6
			not toward edge	1.0
M min. = 0.50M	0.7	M min. = 0.50M	toward edge	0.4
			not toward edge	0.5

GENERAL SPECIFICATIONS

Adhesive resin anchor shall be polyester, epoxy, acrylic, hybrid-urethane as manufactured by MKT Fastening, LLC, #1 Gunnebo Dr., Lonoke, AR 72086.

INSTALLATION

Adhesive resin anchors shall be installed in holes drilled with carbide tipped bits conforming to ANSI specification B212.15-94. Minimum installation depth and hole preparation shall be as recommended by manufacturer.

FOR REDUCED SPACING AND EDGE DISTANCES

- 1 Linear interpolation is allowed for edge distances falling between 0.50M and 1.00M, and anchor spacing falling between 0.50S and 1.00S.
- 2 Load reduction factors should be combined where applicable. Where three or more anchors are used, spacing reduction factors must be multiplied together. Where two or more edge distances affect performance, edge reduction factors must be multiplied together. When a group of anchors is affected by both reduced spacing and reduced edge distances, the edge and spacing reduction factors must be multiplied together.

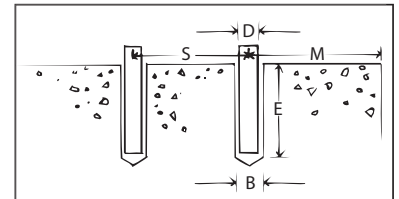

TERMS & CONDITIONS OF SALE

MINIMUM BILLING

Minimum billing is \$100.00. Concrete Anchor Systems (USE - MKT), Adhesive Fastening Systems (Liquid Roc).

FREIGHT POLICY

All freight charges are prepaid from our shipping warehouse to one destination where the total order exceeds \$1,500.00 (Hawaii and Puerto Rico prepaid on \$4000.00). Air freight shipments are F.O.B. our shipping location. We will absorb all freight costs of back orders if the original order qualified for prepaid freight. Our responsibility ceases when the carrier signs the shipping manifest. All claims for shortages and or damage must be settled by the distributor and the carrier. Please note: Liquid Roc 300 cannot be shipped parcel post, 1st class mail, air parcel post, bus, commercial air lines or UPS air from external warehouses. USE - MKT, Liquid Roc and EP800 products may be combined to meet freight minimums.

RETURNS & SHORTAGES

All returns must be preapproved by the MKT Customer Service Department at 1-800-336-1640 with appropriate R.G.A. number. Returned product must be of current production and in new and saleable condition. Adhesive materials can only be returned within 30 days from the date of original purchase. All returns are subject to a 25% restocking fee. If inspection shows that the product must be replaced, repackaged, or otherwise reworked, a reworking charge will be made. Credits for returned merchandise will be issued at the distributors purchase price or current price, whichever is lower. Credits will be issued against future orders. Notification of shipping and invoice discrepancies must be made within 30 days in writing.

Terms are net 30 days. Accounts not paid within 30 days from the net due date will be charged a 1-1/2% per month service charge or applicable state interest allowed.

LIMITATION OF LIABILITY

Neither seller nor manufacturer has any knowledge or control concerning the purchaser's use of the product. No express warranty is made by seller or manufacturers with respect to the results of any use of the product. NO IMPLIED WARRANTIES, INCLUDING BUT NOT LIMITED TO AN IMPLIED WARRANTY OF MERCHANTABILITY, OR AN IMPLIED WARRANTY OF FITNESS FOR A PARTICULAR PURPOSE, ARE MADE WITH RESPECT TO THIS PRODUCT. Neither seller nor manufacturer assumes any liability for personal injury, loss or damage resulting from the use of this product. In the event that the product shall prove defective, buyers exclusive remedy shall be as follows: Seller or manufacturer shall, upon written request of buyer, replace any Qty. of the product which is proven to be defective, or shall, at its option, refund the purchase price for the product upon return of the product. PURCHASER'S TRAINING OBLIGATION AND INDEMNIFICATION LIABILITY FOR POWDER ACTUATED TOOLS As a term of sale or transfer, the purchaser recognizes that powder tools can be dangerous instruments if placed in the hands of untrained personnel. Purchaser therefore agrees that it has the obligation to properly train all who will use or reasonably be expected to use or handle any powder tools sold or transferred herein. Purchaser agrees that only individuals who have been properly trained in the safe and proper use and handling of the powder tool(s) sold or transferred herein, will be permitted to handle or operate same. PURCHASER AGREES TO INDEMNIFY MKT FASTENING WITH RESPECT TO ANY AND ALL LIABILITY FOR INJURY OR DAMAGE TO PROPERTY OR PERSON (INCLUDING BUT NOT LIMITED TO TOOL OPERATORS) OCCASIONED BY THE USE OR OPERATION OF POWDER ACTUATED TOOLS BY ANY PERSON, INCLUDING ANY EMPLOYEE OR SUBCONTRACTOR, WITHOUT PROPER TRAINING AND CERTIFICATION.

MKT Fastening agrees to provide Purchaser with authorized training upon request in order to assist Purchaser with its obligation to train as set forth above. However, MKT's offer to train, whether or not accepted by the Purchaser, in no manner diminishes Purchaser's obligation to train as set forth above. Purchaser's training obligation continuously remains with Purchaser and extends to any and all individuals who may be called upon in the future to operate or handle the tools sold or transferred herein.

WARRANTY

ALL WARRANTIES OF THE PRODUCTS DESCRIBED HEREIN, EXPRESSED OR IMPLIED, INCLUDING THE WARRANTIES OF MERCHANTABILITY AND FITNESS FOR PARTICULAR PURPOSES ARE SPECIFICALLY EXCLUDED EXCEPT FOR THE FOLLOWING: THIS IS THE SOLE WARRANTY OF MKT FASTENING AND THE SOLE REMEDY AVAILABLE TO DISTRIBUTORS OR BUYER.

PRICES

Prices are subject to change without notice. Backordered items will be billed at the prices that were in effect at the time of original order.



SOLID CONNECTIONS

COME IN MANY FORMS

AVAILABLE.



AMERICAN-MADE.



APPROVED.



SINCE 1911



A SOLID CONNECTION[®]

MKTFASTENINGUSA.COM